

BRASCH



**Explosion-Proof
and Fan-Forced
Unit Heaters**

Introduction/Table of Contents

Brasch offers commercial and industrial electric heating and control systems that set the industry standard for excellence. The company's heating solutions reflect more than 85 years of innovation, product quality and efficient service.



This catalog features Brasch's complete line of explosion-proof and fan-forced electric unit heaters. Our products include 233 Series and 236 Series Explosion-proof Unit

Heaters; a 254 Series explosion-proof convector; the 234 Series Washdown/Corrosion Resistant Unit Heater; and several types of standard unit heaters.





Brasch's quality is matched only by its customer service and support. With its quick-ship delivery program, Brasch provides the products you need.

Use of Electric Heaters in Hazardous Locations 3



Explosion-proof Unit Heaters

	Comparison Chart	6-7
	233 Series Explosion-proof Unit Heaters (233)	8-14
	236 Series Explosion-proof Unit Heaters (236)	15-17
	254 Series	18-25

Fan Forced Heaters

	Comparison Chart	26
	234 Series Washdown/Corrosion Resistant Unit Heaters	27-30
	238 Series Industrial Unit Heater	31-33
	BTUR 240 Series Unit Heater	34-38
	925 Series Unit Heater	39-40

Plenum Heaters

	Confined Space Unit Heaters	41-42
	962 Series Plenum Rated Units for Enclosed Spaces	43-46
	963 Series Low Profile Plenum Heater	47-50
	Limited Warranty	51
	Warranty Period	52

*Optional factory installed disconnect switches have been sized in accordance to current UL2021 standards.

*All field installed and factory installed electrical component options are listed with their maximum voltage and maximum amperage ratings. They can be used with heaters rated up to their maximum ratings.

Use of Electric Heaters IN HAZARDOUS LOCATIONS

Introduction

Hazardous locations are those areas where a potential for explosion and fire exists due to the presence of flammable gases, vapors, pulverized dusts or ignitable fibers in the atmosphere. Hazardous locations are created from the normal processing of volatile chemicals, gases, coal, grains, etc., or from the accidental failure of storage systems for these materials.

Open flames are not permitted in these locations. The use of electric heating equipment is permitted with two major restrictions: 1) The surface temperature of the equipment cannot exceed the ignition temperature of the hazardous atmosphere and 2) all arc and spark producing devices must be isolated from the atmosphere in an appropriate enclosure.

National Electrical Code Classification

Articles 500 through 516 of the National Electrical Code deal with the definition of hazardous areas and the use or design of electrical equipment used in these locations. Electric heating equipment for hazardous areas is specified based on the NEC class, division, group and ignition temperature or the alternate class and zone classification.

Class

Hazardous locations are divided into the three general classes of vapors/gases, dusts and fibers.

Class I – Locations where the potential for explosion and fire exists due to the presence of flammable gases or vapors in the air. Typical Class I locations include oil or natural gas drilling rigs, petroleum refining or pumping facilities, petrochemical plants, wastewater/sewage treatment plants, solvent extraction plants, paint spraying booths, locations

where open tanks or vats of combustible liquids are present and storage areas for flammable materials.

Class II – Locations where the potential for explosion exists because of finely pulverized flammable dusts suspended in the atmosphere. Typical locations would include coal fired power plants, coal preparation/coal handling facilities, coal mines, grain elevators, flour and feed mills, packaging and handling of pulverized sugar and processing and storage of magnesium and aluminum powder.

Class III – This third classification is primarily a fire hazard where fibers or flyings suspended in the air create a hazard. This would include small pieces of thread-like fiber, sawdust, lint, etc. Typical applications would include textile mills, woodworking plants, cotton gins, cotton seed mills and flax producing plants.

Division

Class I, Class II and Class III areas are further defined in terms of when the hazard occurs. Division 1 and Division 2 occurrences are summarized below.

Division 1 – If the hazard is expected to be present under normal conditions, such as a production or processing facility, the occurrence is designated Division 1. The hazardous atmosphere may be present continuously, intermittently, periodically, or during normal repair or maintenance operations. Division 1 occurrences also include locations where a breakdown in the operation of processing equipment results in the release of hazardous vapors.

Division 2 – If the hazardous material is normally expected to be contained within a closed area, system or container, and would enter the ambient atmosphere only under an abnormal failure, then it is referred to as a Division 2 occurrence.

Hazardous and Corrosive Area Applications

- Aircraft Hangars/Service Areas
- Battery Storage Areas
- Chemical Plants
- Chemical Storage/Handling Areas
- Coal Mines/Preparation Plants
- Control Rooms
- Dry Cleaning Plants
- Dusty Areas Subject to Washdown
- Food Processing Plants (Washdown Areas)
- Foundries
- Gasoline Fueling/Storage Areas
- Grain Elevators
- Hydrogen Atmospheres
- Marine/Shipboard and Landbase Facilities
- Natural Gas (Methane) Atmospheres
- Oil Refineries
- Offshore Drilling Rigs
- Paint Spraying/Storage Areas
- Parking Garages
- Petrochemical Plants
- Pipeline Pumping Stations
- Pulp and Paper Mills
- Sewage/Wastewater Treatment Plants
- Solvent Recovery/Storage Areas
- Utility Plants

Use of Electric Heaters IN HAZARDOUS LOCATIONS

Group

The nature and explosive characteristics of the hazardous material are defined by the NEC group to which it is assigned.

Class I – Hazardous vapors/gas locations include chemicals and other materials that have been divided into four groups based on their ignition temperature and explosive characteristics. (Groups A, B, C and D)

Class II – Hazardous dust locations are divided into three groups based on their ignition temperature and electrical conductivity of the suspended particles.

Group E – Atmospheres containing metal dust, such as aluminum or magnesium.

Group F – Atmospheres containing coal, charcoal or coke dust.

Group G – Atmospheres with grain, flour, starch, combustible plastics or chemical dust.

Class III – Locations have no group definitions.

Ignition Temperature

All electrical equipment is designed not to exceed the ignition temperature of the hazardous atmosphere. The maximum surface temperature for electric heaters is defined by the NEC.

Class and Zone Classifications

Class I, Zone 0 – Locations in which ignitable concentrations of flammable gases or vapors are present continuously or for long periods.

Class I, Zone 1 – Locations in which ignitable concentrations of flammable gases or vapors are likely to exist, may exist frequently or exist as a result of equipment breakdown or faulty operation. Applies to locations adjacent to a Class I, Zone 0 location.

Class I, Zone 2 – Locations in which ignitable concentrations of flammable gases or vapors are not likely to occur under normal operation, exist only for a short period or exist only as a result of accidental failure, such as rupture or breakdown of the container or system, abnormal operation of equipment, failure or abnormal operation of the ventilation equipment. Applies to locations adjacent to a Class I, Zone 1 location.

Material Groups

Group IIC – Atmospheres containing acetylene or hydrogen. Equivalent to a combination of Class I, Group A and Class I, Group B as described in NEC Article 500.

Group IIB – Atmospheres containing acetaldehyde. Equivalent to Class I, Group C as described in NEC Article 500.

Group IIA – Atmospheres containing acetone, ammonia, ethyl alcohol, gasoline, methane or propane. Equivalent to Class I, Group D as described in NEC Article 500.

Product use depends on temperature class. The temperature code indicates the maximum temperature of the exposed surface of the product. For Zone classified dusts the explosion-proof temperature is the maximum surface temperature is shown as e.g. T80°C

Class, Division Classification		Zone Classification	
Temperature Class (T Code)	Maximum Surface Temperature °F (°C)	Temperature Class (T Code)	Maximum Surface Temperature °C
T1	≤ 842 (≤ 450)	T1	≤ 450
T2	≤ 572 (≤ 300)	T2	≤ 300
T2A	≤ 536 (≤ 280)	T3	≤ 200
T2B	≤ 500 (≤ 260)	T4	≤ 135
T2C	≤ 446 (≤ 230)	T5	≤ 100
T2D	≤ 419 (≤ 215)	T6	≤ 85
T3	≤ 392 (≤ 200)		
T3A	≤ 356 (≤ 180)		
T3B	≤ 329 (≤ 165)		
T3C	≤ 320 (≤ 160)		
T4	≤ 275 (≤ 135)		
T4A	≤ 248 (≤ 120)		
T5	≤ 212 (≤ 100)		
T6	≤ 185 (≤ 85)		

Use of Electric Heaters IN HAZARDOUS LOCATIONS

Special Requirements for Electric Heating Equipment used in Hazardous Areas

Electric heating equipment can be economically designed and safely used in hazardous areas if the following special requirements are observed.

1. The surface temperature of the electric heating equipment cannot exceed the ignition temperature of the hazardous atmosphere. To insure that the proper heater has been selected, it is essential that the correct NEC Ignition Temperature Code be specified.

If the temperature code selected is too high, the electric heating system may operate above the ignition point of the application, creating a potentially hazardous condition.

2. All arc and spark-producing control devices must be isolated from the hazardous atmosphere. If it is not economically feasible to locate the control devices in the non-hazardous area, they must be housed in an enclosure that will withstand the pressure of a potential explosion from within the enclosure.
3. All electrical supply connections must be made according to the latest NEC and local code requirements for hazardous locations. This includes the requirement that conduit entering the enclosures must be provided with seals at the enclosure.

CLASS I - HAZARDOUS GAS ATMOSPHERES					CLASS I - HAZARDOUS GAS ATMOSPHERES				
Group	Material	Ignition Temp.		NEC Code	Group	Material	Ignition Temp.		NEC Code
		°F	°C				°F	°C	
A	Acetylene	581	305	T2	D	Methyl Isobutyl Ketone	840	448	T2
B	Acrolein (Inhibited)	428	220	T2D		2-Methyl-1-Propanol (Isobutyl Alcohol)	780	415	T2
	Butadiene	788	420	T2		Petroleum Naptha	550	288	T2A
	Ethylene Oxide	804	429	T2		Pyridine	900	482	T1
	Hydrogen	932	500	T1		Octanes	403	206	T3
	Propylene Oxide	840	449	T2		Pentanes	500	260	T2B
	Propyl Nitrate	347	175	T3B		1-Pentanol (Amyl Alcohol)	650	343	T2
C	Acetaldehyde	347	175	T3B		Propane	842	450	T1
	Allyl Alcohol	713	378	T2		1-Propanol (Propyl Alcohol)	775	412	T2
	Carbon Monoxide	1128	609	T1		2-Propanol (Isopropyl Alcohol)	750	399	T2
	Cyclopropane	928	498	T1		Propylene	851	455	T1
	Ethylene	842	450	T1		Styrene	914	490	T1
	Hydrogen Cyanide	1000	538	T1		Toluene	896	480	T1
	Hydrogen Sulfide	500	260	T2B		Vinyl Acetate	756	402	T2
	2-Nitropropane	802	428	T2		Vinyl Chloride	882	472	T1
	Tetrahydrofuran	610	321	T2		Xylenes	867-984	463-528	T1
D	Acetic Acid (Glacia)	867	463	T1	CLASS II - HAZARDOUS DUST ATMOSPHERES				
	Acetone	869	465	T1	Group	Material	Ignition Temp.		NEC Code
	Ammonia, Anhydrous	1204	651	T1			°F	°C	
	Benzene	928	498	T1	E	Aluminum, A422 Flake	608	320	T2
	Butane	550	287	T2A		Calcium Silicide	1004	540	T1
	1-Butanol (Butyl Alcohol)	650	343	T2		Manganese	464	240	T2C
	2-Butanol (Secondary Butyl Alcohol)	761	405	T2		Magnesium, Grade B, Milled	806	430	T2
	Ethane	882	472	T1	F	Charcoal	356	180	T3A
	Ethanol (Ethyl Alcohol)	685	363	T2		Coal, Kentucky Bituminous	356	180	T3A
	Ethyl Acetate	800	427	T2		Coal, Pittsburgh Experimental	338	170	T3B
	Ethylene Dichloride	775	413	T2		Pitch, Petroleum	1166	630	T1
	Gasoline (56-60 Octane)	536	280	T2A	G	Alkyl Ketone Dimer Sizing Compound	320	160	T3C
	Gasoline (100 Octane)	853	456	T1		Corn	482	250	T2C
	Heptanes	399	204	T3		Corn Starch, Modified	392	200	T3
	Hexanes	437	235	T2D		Polyurethane Foam, Fire Retardant	734	390	T2
	Isoprene	428	220	T2D		Shellac	752	400	T2
	Isopropyl Ether	830	443	T2		Soy Flour	374	190	T3A
	Methane (Natural Gas)	900-1170	482-632	T1		Sugar, Powdered	698	370	T2
	Methanol (Methyl Alcohol)	867	454	T1		Sulfur	428	220	T2D
	3-Methyl-1-Butanol (Isoamyl Alcohol)	662	350	T2		Wheat	428	220	T2D
	Methyl Ethyl Ketone	759	404	T2		Wood Flour	500	260	T2B

The materials given are found in NFPA 497, 1991 and NFPA 325, 2001.

Comparison Chart

Only Brasch offers a selection of explosion-proof heater constructions to meet your specific application.

233 Series

Our most popular and versatile construction has a broad range of stock designs, special options and the industry's lowest Ignition Temperature Code rating, 320°F (160°C).

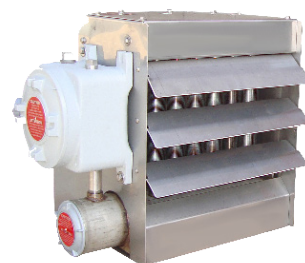

Features	233 Series
Hazardous Location NEC Classifications	Class I, Divisions 1 and 2, Groups C and D Class II, Divisions 1 and 2, Groups E, F, and G Class 1, Zones 1 and 2, Groups IIB
Ignition Temperature Code	T3C 320°F (160°C)
KW Range	Up to 35 KW
Standard Built-in Overtemperature Protection	Dual overtemperature protection with automatic and manual reset thermal cutouts
Other Standard Built-in Controls	Controlling contactor, control circuit transformer
Standard Control Voltage	24V
Single Point Line Voltage Connection for Incoming Power	Yes
Optional Built-in Controls	
Thermostat	Yes
Disconnect Switch	Yes
Selector Switch	Yes
Manual Reset Cutout	Standard
“Heater On” Pilot Light	Yes
“Warning” Pilot Light	Yes
Control Circuit Transformer	Standard
Standard Construction	
Heater Assembly	Liquid-to-air heat exchanger, steel tube with aluminum fins, propylene glycol, immersion heater
Cabinet/Housing	Powder coated galvanized steel
NEMA 7, 9 Control Enclosure	Cast aluminum
Mounting Brackets	Wall, ceiling or pole mounting kits (optional)
Optional Constructions	
Dirty Duty Corrosion Resistant	Choice of 316SS Construction or Heresite® coating
Wet Location	Suitable for IP55 wet locations
50 Hertz Motor	Yes
Agency Approvals	
	CSA c _{us}

Comparison Chart

236 Series

The industry's smallest and most economical design for Class I, Group D applications up to 12 KW.



254 Series Convector

Small, compact design with a wide range of optional built-in controls.

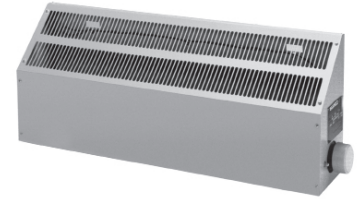

236 Series	254 Series Convector
Class I, Divisions 1 and 2, Group D Class 1, Zones 1 and 2, Group IIA	Class I, Divisions 1 and 2, Groups B, C and D Class II, Divisions 1 and 2, Groups E, F, and G Class 1, Zones 1 and 2, Groups IIC
T3 392°F (200°C) (Varies with KW)	T3C 320°F (160°C) (Varies with classification)
Up to 12 KW	Up to 9.5 KW
Primary and secondary automatic reset cutouts with fan relay	Primary automatic reset cutout
Controlling contactor	None
120V	Maximum 277V
Separate 120V motor line required	Yes
Yes	Yes
No	No
No	No
Yes	No
No	No
No	No
No	Yes
Stainless steel finned tubular elements	Heater core enclosed in copper tube with large aluminum fins
Stainless steel	Powder coated galvanized steel
Cast aluminum	Cast aluminum
Swivel mounting bracket (standard)	Wall mounting bracket (standard)
Yes	Wet locations (Type 3) iridite coated elements
No	Wet locations (Type 3) iridite coated elements
No	N/A
CSA _{US}	CSA _{US}

233 Series

UNIT HEATER

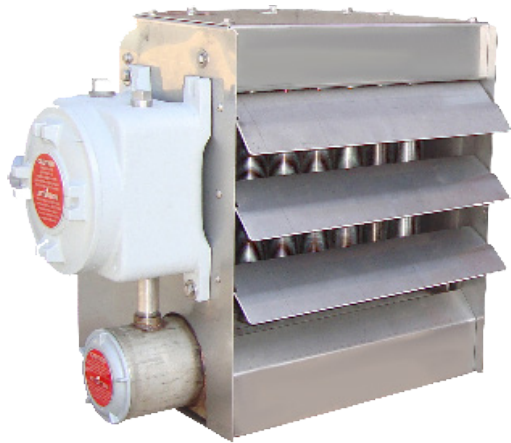

Applications

- Aircraft Hangars/Service Areas
- Chemical Storage/Handling Areas
- Coal Preparation Plants
- Compressor Stations
- Grain Elevators
- Oil Refineries and Rigs
- Paint Storage Areas
- Petrochemical Plants
- Sewage Pump Stations/ Treatment Plants (Option C1 recommended)
- Spray Booths

Class I, Divisions 1 and 2, Groups C and D
Class II, Divisions 1 and 2, Groups E, F and G
Class I, Zones 1 and 2, Group IIB
Temperature Code T3C, 320°F (160°C)

Brasch's 233 Series explosion-proof unit heater is designed with both safety and versatility in mind. Unique 233 Series features include:

- Industry's Lowest Ignition Temperature Code Rating: T3C, 320°F (160°C)
- Dual Overtemperature Protection: With both automatic and manual reset overtemperature cutouts for additional safety.
- Optional wet location construction, which includes IP55 motor, type 4 outdoor rated enclosure and meets rain-tight requirements of UL 1004-1.
- Nontoxic Propylene Glycol Heat Transfer Fluid
- Low 70 PSIG Relief Valve Setting: This assures that in an emergency, the initial escaping vapor temperature remains below the 320°F (160°C) ignition temperature.
- Corrosion Resistant Options: Brasch offers three constructions suitable for most applications.

Standard construction for use in dry non-corrosive areas includes: welded steel heat exchanger; powder-coated cabinet.

A 316 stainless steel construction suitable for Waste Water Treatment Plants includes: 316 stainless steel heat exchanger, headers and tubes with aluminum fins; stainless steel cabinet; corrosion resistant hardware.

Third construction is suitable for use in Chemical Plants where chlorides are present and includes: Heresite® coated heat exchanger, cabinet, fan blade; corrosion resistant hardware.

Standard Construction Features

Heat Exchanger – Efficient liquid-to-air design utilizes an all welded steel headers and finned tube construction with spiral wound aluminum fins. Industrial grade Brasch heating elements are immersed in a nontoxic, inhibited, propylene glycol heat transfer fluid that provides freeze protection down to -49°F (-45°C). The heat exchanger is hydrostatically tested at 350 psig. A pressure relief valve provides excess pressure protection and is set at 70 psig.

Fan Motor Assembly – Consists of an explosion-proof motor fitted with an aluminum fan blade. The motor has double-shielded, permanently lubricated ball bearings and automatic reset line breaking thermal overload protection. Motors furnished on standard units operate at line voltage and are prewired to the control enclosure so separate field wiring to the motor is not required. The standard motor is rated for

Class I, Groups C and D, Class II, Groups F and G. The minimum operating temperature is -14°F (-25°C) and the minimum storage temperature is -49°F (-45°C). Optional motor ratings are described on page 9.

Cabinet/Louvers – Industrial grade, corrosion resistant construction fabricated from beige powder coated 14-gauge galvanized steel. The adjustable louvers have minimum opening safety stops.

Controls – Factory mounted on the unit heater. Standard built-in controls include automatic and manual reset overtemperature cutouts, controlling magnetic contactor, and 24-volt control circuit transformer housed in a NEMA 7, 9 cast aluminum enclosure.

Factory Built-in Options

Code	Option	Description	Availability Code (2)
C1	316 Stainless Steel Corrosion-Resistant Construction (Waste Water Treatment Plants)	316 Stainless steel heat exchanger with aluminum fins, 316 stainless steel cabinet; aluminum fan blade; cast aluminum NEMA 7, 9 control enclosure; corrosion-resistant hardware; corrosion-resistant protective coated motor, which has passed the ASTM B117 salt-spray test.	C
C2	Dirty Duty Corrosion-Resistant Construction (Chemical Plants)	Heresite® coated heat exchanger, cabinet and fan blade; cast aluminum NEMA 7, 9 control enclosure; corrosion-resistant hardware; corrosion-resistant protective coated motor which has passed the ASTM B117 salt-spray test.	C
D	Disconnect Switch	Factory installed on the unit heater above the control enclosure. This is an inexpensive and positive way to meet NEC/CEC requirements for a disconnecting means within sight of the heater.	AS
E	Group E (Metal Dust) Construction	Class II, Group E (Metal Dust) Construction Temperature Code T3C, 320°F (160°C).	C
K	“Warning” Pilot Light	Indicates when the thermal cutouts have tripped and the unit heater needs servicing.	AS
L	“Heater On” Pilot Light	Indicates when the electric heating elements are energized.	AS
M	Manual Reset Thermal Cutout with Backup Contactor	A pilot duty manual reset thermal cutout with a backup contactor is provided for independent secondary over-temperature protection. This option cannot be provided if option Code S or V are also specified.	AS
S	Auto/Fan Selector Switch	A two-position switch wired to the control circuit for auto (automatic heat) and fan only control. This selector switch cannot be provided if option Code M or V are also specified.	AS
S1	Built-In Controls for Remote Auto/Fan Selector Switch	Unit is prewired for field addition of remote auto/fan selector switch. This option cannot be provided if Code M or V are also specified.	AS
T	Adjustable Thermostat	Factory installed and prewired to the control enclosure. Thermostat is adjustable from 50° to 90°F (10° to 32°C) range.	AS
T1	Adjustable Thermostat for Wet Locations	Factory installed and prewired to the control enclosure. Thermostat is adjustable from 40° to 80° F (5° to 25° C) range. Can be specified for all constructions.	AS
V	120 Volt Control Circuit	Can be provided when required for special external thermostat circuit. This option cannot be provided if option Code S or M are also specified. Nor can both K and L be specified.	AS
W	Wet Location Construction Features – IP55	Unit provided with components suitable for IP55 wet locations. Requires dirty duty corrosion-resistant or 316 stainless steel corrosion-resistance construction option.	AS

(2) AS = Assembly Stock, C = Custom. Assembly Stock heaters ordered with custom options are subject to longer delivery.

233 Series

UNIT HEATER

Accessory Items

233 Series Heater Mounting Kits

These are available for ceiling, wall and pole mounting configurations as described below. Specify type required and catalog number at time of order entry.

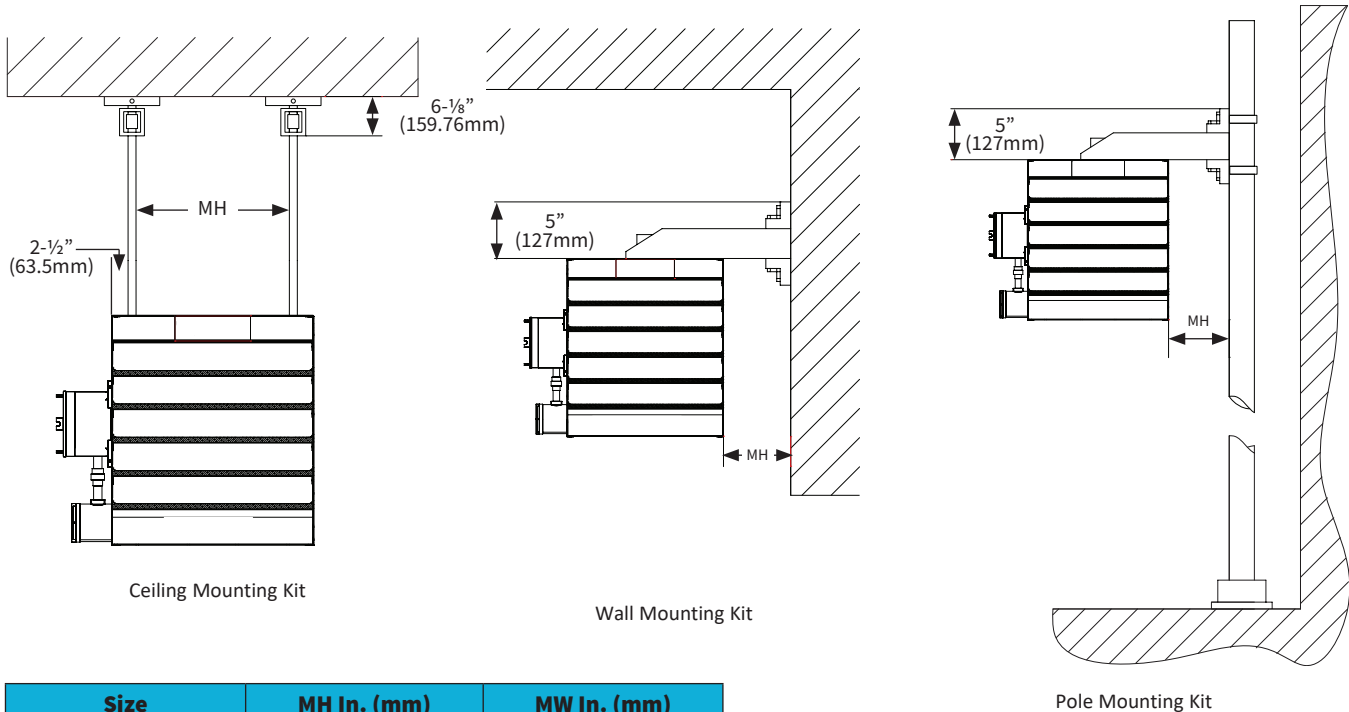

Size	MH In. (mm)	MW In. (mm)
1	11.063 (281)	9 (228.6)
2	15.063 (382.6)	7 (177.8)
3	19.063 (484.2)	5 (127)

Unit Heater Mounting Kits (One kit required per heater) Standard Mounting Kits for use in most applications

Catalog Number	Description	Availability Code (2)
BH-1022451	Ceiling Mounting Kit, for Frame Size 1, 2, 3	AS
BH-1022454	Wall Mounting Kit, for Frame Size 1, 2, 3	
BH-1022457	Pole Mounting Kit, for Frame Size 1, 2, 3	

Optional Mounting Kits for Option C1 or C2 heaters

Catalog Number	Description	Availability Code (2)
BH-1022451-S	Corrosion Resistant Ceiling Mounting Kit, for Frame Size 1, 2, 3	AS
BH-1022454-S	Corrosion Resistant Wall Mounting Kit, for Frame Size 1, 2, 3	
BH-1022457-S	Corrosion Resistant Pole Mounting Kit, for Frame Size 1, 2, 3	

(2) AS = Assembly Stock, C = Custom. Assembly Stock heaters ordered with custom options are subject to longer delivery.

233 Series

UNIT HEATER

Accessory Remote Thermostat

Catalog Number	Switch Type	Description	Type	Ratings	Temp. Range °F (°C)	Availability Code
1007002	Bimetal	Class 1, Div. 1, Groups C & D Class II, Div. 1, Groups E, F, & G	SPDT	125-277V, 22A	50-90 (10-32)	AS
BH-1024754	Bulb and Capillary with Internal Set Point Adjustment	Class 1, Div. 1, Groups B, C & D Class II, Div. 1, Groups E, F, & G	SPDT	120-240V, 25A 277V, 22A	40-120 (5-49)	
BH-1025396	Bulb and Capillary with Internal Set Point Adjust- ment	Corrosion-Resistant Class 1, Div. 1, Groups B, C, & D Class II, Div. 1, Groups E, F & G	SPST	120-240V, 25A 277V, 22A	40-120 (5-49)	
1036506	Bimetal	Class I, Div. 1, Groups C & D Class II, Div. 1, Groups E, F, & G Class III IP66, Type 4	SPDT	480V, 15A	40-80 (5-25)	AS

Remote Fan Switch

Catalog Number	Switch Type	Description	Hubs	Ratings	Availability Code
1001744	2-Position	Class I, Div. 1, Groups C & D Class II, Div. 1, Groups E, F, & G Class III	(2) 3/4" NPT Hubs	120/277V 30A	AS
1031042	2-Position	Class I, Div. 1, Groups C & D Class II, Div. 1, Groups E, F, & G Class III NEMA 4X	(2) 3/4" NPT Hubs	110V 6A	

233 Series

UNIT HEATER

Dimensions, Airflows and Weights

Frame Size		Size 1	Size 2	Size 3
Overall Heater Dimensions	'X' In. (mm)	22.50 (571.50)	22.50 (571.50)	22.75 (577.85)
	'Y' In. (mm)	19.375 (492.125)	23.375 (593.725)	27.375 (695.325)
	'Z' In. (mm)	16.063 (408)	20.188 (512.775)	24.188 (614.375)
Weight	Net Lbs. (kgs)	110 (49.89)	150 (68.03)	190 (86.18)
	Shipping Lbs (kgs)	130 (58.96)	169 (76.65)	216 (97.97)

60 Hertz Heaters

KW Range		3 - 5	7.5 - 10	15	20	25	30 - 35
Airflow Characteristics	Air Volume CFM (cubic meter/hr.)	650 (1104)	850 (1444)	1800 (3058)	3110 (5283)	3110 (5283)	3850 (6541)
	Air Throw Feet (m)	15 (4.5)	25 (7.6)	45 (13.7)	65 (19.8)	65 (19.8)	75 (22.8)
Motor/Fan	RPM	1725					
	HP	1/4				1/2	
	Fan Blade Dia. In. (mm)	12 (304.8)		16 (406.4)		20 (508)	

50 Hertz Heaters

KW Range		2.5 - 4.2	6.3 - 8.4	12.5	16.7	21 - 25	
Airflow Characteristics	Air Volume CFM (cubic meter/hr.)	550 (934)	700 (1189)	1500 (2549)	1500 (2549)	2600 (4417)	
	Air Throw Feet (m)	13 (4)	22 (7)	39 (12)	39 (12)	57 (17)	
Motor/Fan	RPM	1438					
	HP	1/4				1/2	
	Fan Blade Dia. In. (mm)	12 (304.8)		16 (406.4)		20 (508)	

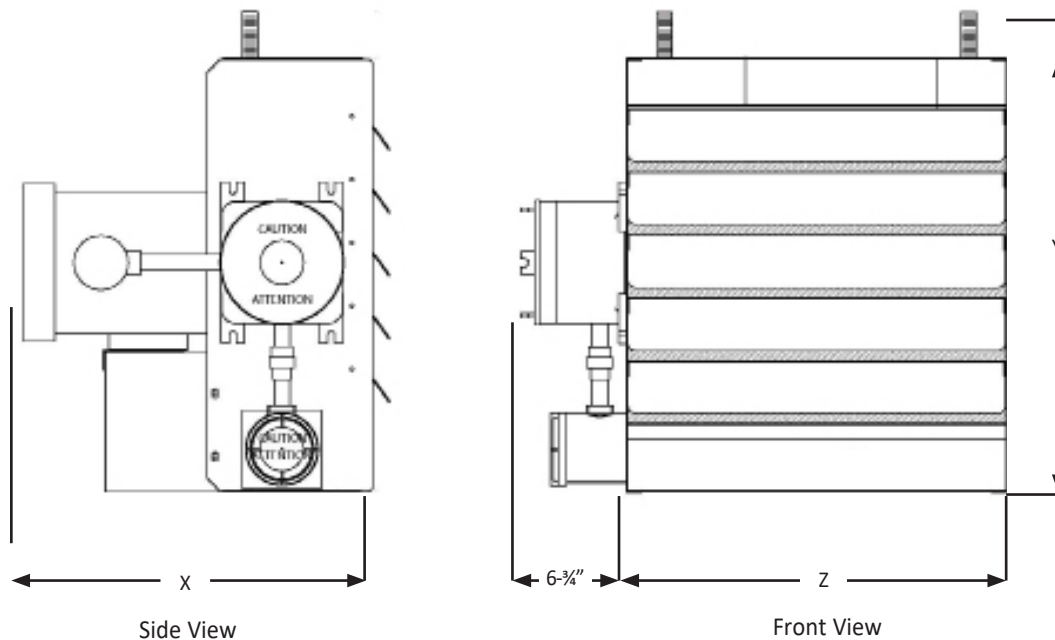

233 Series

UNIT HEATER



233 Series Unit Heater Listing 60 Hz

Class I, Divisions 1 and 2, Groups C and D
Class II, Divisions 1 and 2, Groups E, F and G
Class I, Zones 1 and 2, Group IIB
Temperature Code T3C, 320°F (160°C)

KW	Volts	Phase	Total Amps (1)	Frame Size	Approximate Air Temperature Rise °F (°C)	Catalog Number	Availability (2)
3	208	1	17	1	15 (8)	BH-233-FA-0036C	AS
	240	1	15	1	15 (8)	BH-233-FA-0036J	
	208	3	10	1	15 (8)	BH-233-FA-0036D	
	240	3	9	1	15 (8)	BH-233-FA-0036K	
	480	3	5	1	15 (8)	BH-233-FA-0036U	
	600	3	4	1	15 (8)	BH-233-FA-0036Z	
5	208	1	26	1	25 (13)	BH-233-FA-0056C	
	240	1	23	1	25 (13)	BH-233-FA-0056J	
	208	3	16	1	25 (13)	BH-233-FA-0056D	
	240	3	14	1	25 (13)	BH-233-FA-0056K	
	480	3	7	1	25 (13)	BH-233-FA-0056U	
	600	3	6	1	25 (13)	BH-233-FA-0056Z	
7.5	208	1	38	1	28 (16)	BH-233-FA-0086C	
	240	1	34	1	28 (16)	BH-233-FA-0086J	
	208	3	23	1	28 (16)	BH-233-FA-0086D	
	240	3	20	1	28 (16)	BH-233-FA-0086K	
	480	3	10	1	28 (16)	BH-233-FA-0086U	
	600	3	9	1	28 (16)	BH-233-FA-0086Z	
10	240	1	44	1	38 (21)	BH-233-FA-0106J	
	208	3	30	1	38 (21)	BH-233-FA-0106D	
	240	3	26	1	38 (21)	BH-233-FA-0106K	
	480	3	13	1	38 (21)	BH-233-FA-0106U	
	600	3	11	1	38 (21)	BH-233-FA-0106Z	
15	208	3	44	2	27 (15)	BH-233-FB-0156D	
	240	3	38	2	27 (15)	BH-233-FB-0156K	
	480	3	19	2	27 (15)	BH-233-FB-0156U	
	600	3	16	2	27 (15)	BH-233-FB-0156Z	
20	480	3	25	2	35 (19)	BH-233-FB-0206U	
	600	3	21	2	35 (19)	BH-233-FB-0206Z	
25	480	3	31	3	26 (14)	BH-233-FC-0256U	
	600	3	25	3	26 (14)	BH-233-FC-0256Z	
30	480	3	37	3	25 (13)	BH-233-FC-0306U	
	600	3	30	3	25 (13)	BH-233-FC-0306Z	
35	480	3	43	3	29 (16)	BH-233-FC-0356U	
	600	3	35	3	29 (16)	BH-233-FC-0356Z	

(1) Total Amps = Heating element amps and motor amps.

(2) AS = Assembly Stock, C = Custom. Assembly Stock heaters ordered with custom options are subject to longer delivery.

233 Series

UNIT HEATER

233 Series Unit Heater Listing 50 Hz

Class I, Divisions 1 and 2, Groups C and D
 Class II, Divisions 1 and 2, Groups E, F and G
 Class I, Zones 1 and 2, Group IIB
 Temperature Code T3C, 320°F (160°C)



KW	Volts	Phase	Total Amps (1)	Frame Size	Approximate Air Temperature Rise °F (°C)	Catalog Number	Availability (2)
2.5	220	1	14	1	14 (8)	BH-233-FA-0036E	C
	220	3	9	1	14 (8)	BH-233-FA-0036F	
	380	3	6	1	14 (8)	BH-233-FA-0036G	
	400	3	6	1	14 (8)	BH-233-FA-0036H	
	415	3	5	1	14 (8)	BH-233-FA-0036I	
4.2	220	1	21	1	24 (13)	BH-233-FA-0056E	
	220	3	13	1	24 (13)	BH-233-FA-0056F	
	380	3	9	1	24 (13)	BH-233-FA-0056G	
	400	3	8	1	24 (13)	BH-233-FA-0056H	
	415	3	7	1	24 (13)	BH-233-FA-0056I	
6.3	220	1	31	1	28 (16)	BH-233-FA-0076E	
	220	3	19	1	28 (16)	BH-233-FA-0076F	
	380	3	12	1	28 (16)	BH-233-FA-0076G	
	400	3	11	1	28 (16)	BH-233-FA-0076H	
	415	3	10	1	28 (16)	BH-233-FA-0076I	
8.4	220	1	40	1	38 (21)	BH-233-FA-0096E	
	220	3	24	1	38 (21)	BH-233-FA-0096F	
	380	3	15	1	38 (21)	BH-233-FA-0096G	
	400	3	13	1	38 (21)	BH-233-FA-0096H	
	415	3	13	1	38 (21)	BH-233-FA-0096I	
12.5	220	3	35	2	26 (14)	BH-233-FB-0136F	
	380	3	21	2	26 (14)	BH-233-FB-0136G	
	400	3	19	2	26 (14)	BH-233-FB-0136H	
	415	3	18	2	26 (14)	BH-233-FB-0136I	
16.7	220	3	46	2	35 (19)	BH-233-FB-0176F	
	380	3	28	2	35 (19)	BH-233-FB-0176G	
	400	3	25	2	35 (19)	BH-233-FB-0176H	
	415	3	24	2	35 (19)	BH-233-FB-0176I	
21	380	3	33	3	26 (14)	BH-233-FC-0216G	
	400	3	32	3	26 (14)	BH-233-FC-0216H	
	415	3	31	3	26 (14)	BH-233-FC-0216I	
25	380	3	39	3	30 (17)	BH-233-FC-0256G	
	400	3	37	3	30 (17)	BH-233-FC-0256H	
	415	3	36	3	30 (17)	BH-233-FC-0256I	

(1) Total Amps = Heating element amps and motor amps.

(2) AS = Assembly Stock, C = Custom. Assembly Stock heaters ordered with custom options are subject to longer delivery.

236 Series

UNIT HEATER



Class I, Divisions 1 and 2, Group D
Class I, Zones 1 and 2, Group IIA

Brasch's 236 Series explosion-proof unit heater is designed with both size and economy in mind. 236 Series advantages and unique features include:

- **236 Series Size:** This small design is only 13 inches wide, which makes it ideal for applications where limited space is available.
- **Low Cost:** The 236 Series design offers the most economical solution for heating small Class I, Group D hazardous areas. It is a cost effective alternative to the use of explosion-proof convection heaters.
- **Redundant Overtemperature Protection:** Primary and secondary automatic reset thermal cutouts for additional safety.
- **Stainless Steel Construction:** Provides superior corrosion resistant protection. Optional Dirty Duty construction adds polyester powder coating to all aluminum parts for use in corrosive applications.

Applications

- Chemical Storage/ Handling Areas
- Sewage/Wastewater Treatment Plants
- Compressor Stations
- Spray Booths
- Oil Platforms and Refineries

Standard Construction Features

Heating Elements – Industrial grade, Type 304 stainless steel finned tubular heating elements are manufactured by Brasch.

Terminal Enclosure – A NEMA 7, 9 cast aluminum enclosure with a threaded bottom cover permits easy access to the built-in controls from underneath the heater.

Housing – Round, 16-gauge stainless steel shroud.

Grilles – An adjustable stainless steel louvered outlet grille directs airflow 45° up or down and a heavy gauge stainless steel rear grille protects against accidental contact with the fan blade.

Stainless Steel Swivel Mounting Bracket – Supplied as standard with all 236 Series explosion-proof unit heaters. This multi-purpose bracket can be used for either wall or ceiling mounting.

Built-In Controls – Include primary and secondary automatic reset overtemperature cutouts, controlling contactor, and a time delay relay which keeps the fan running to cool the heating elements after they have been de-energized.

Fan Motor Assembly – Consists of a 120-volt, 1-phase 60 hertz motor fitted with an aluminum fan blade. The totally enclosed motor is UL Listed for Class I, Group D applications and includes permanently lubricated ball bearings and built-in thermal overload protection. The motor is factory wired into the enclosure to reduce field wiring, but requires a separate 120-volt power supply.

236 Series

UNIT HEATER

Custom Options

Code	Option	Description	Availability Code (2)
C	Dirty Duty Corrosion Resistant Construction	Includes polyester powder coated fan blade, wiring conduit and fittings, NEMA 4X, 7, 9 enclosure.	C
M	Manual Reset Cutout	Can be specified to replace secondary automatic cutout.	C
T	Adjustable Thermostat	Factory installed and prewired to the control enclosure. Thermostat is adjustable from 50° to 90°F (10° to 32°C) range.	C

(2) AS = Assembly Stock, C = Custom Assembly Stock heaters ordered with custom options are subject to longer delivery.

Dimensions, Airflows and Weights

KW		3	5	7	10	12
Ignition Temperature Code		T3	T2C	T2	T1	T1
Approximate Air Temperature Rise °F (°C)		9 (5)	15 (8)	22 (12)	31 (17)	37 (21)
Airflow Characteristics	Air Volume CFM (cubic meters/hr)	1050 (1784)	1050 (1784)	1050 (1784)	1050 (1784)	1050 (1784)
	Air Throw Feet (m)	25 (8)	25 (8)	25 (8)	25 (8)	25 (8)
	Outlet Velocity FPM (meters/min)	1140 (348)	1140 (348)	1140 (348)	1140 (348)	1140 (348)
Motor/Fan	RPM	1725	1725	1725	1725	1725
	HP	1/6	1/6	1/6	1/6	1/6
	Fan Blade Dia. Inch (cm)	12 (31)				
Weight	Net Lbs (kgs)	96 (44)				
	Shipping Lbs (kgs)	110 (50)				

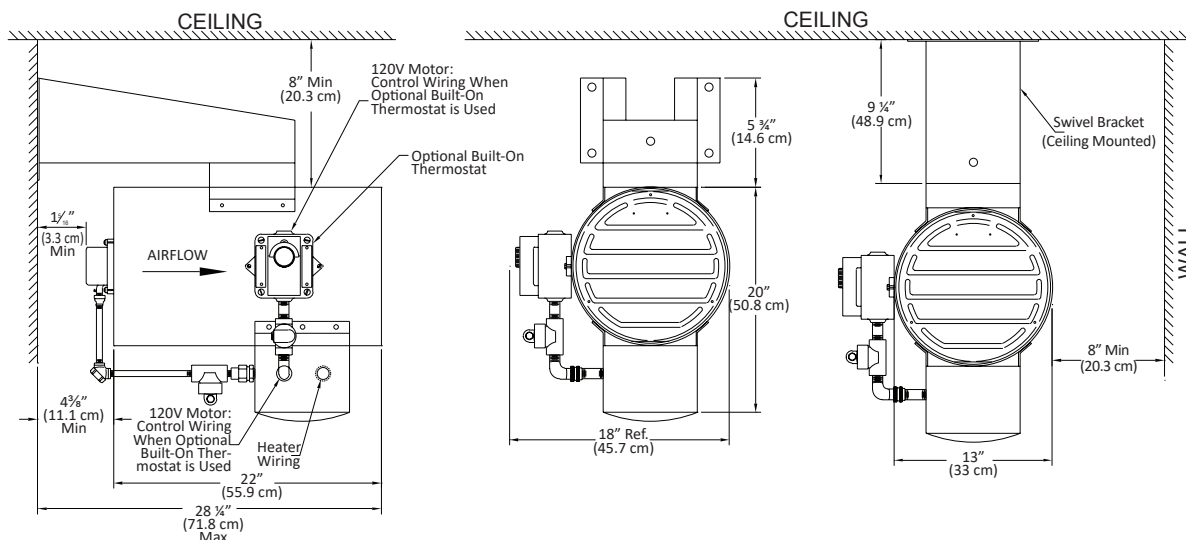

Standard Wall and Ceiling Installation with Swivel Mounting Bracket

236 Series

UNIT HEATER

236 Series Unit Heater Listing

Class I, Divisions 1 and 2, Group D
Class I, Zones 1 and 2, Group IIA



Ignition Temperature Code °F (°C)	KW	Volts	Phase	Heater Amps (1)	Catalog Number	Availability Code (2)
T3 392 (200)	3	208	1	14.5	BH-236-F01T-0037C-7300	C
		240	1	12.5	BH-236-F01T-0037J-7301	C
		480	1	6.3	BH-236-F01T-0037T-7302	C
		208	3	8.4	BH-236-F01T-0037D-7303	C
		240	3	7.3	BH-236-F01T-0037K-7304	C
		480	3	3.7	BH-236-F01T-0037U-7305	C
		600	3	2.9	BH-236-F01T-0037Z-7306	C
T2C 446 (230)	5	208	1	24.1	BH-236-F01T-0055C-7307	C
		240	1	20.9	BH-236-F01T-0055J-7308	C
		480	1	10.5	BH-236-F01T-0055T-7309	C
		208	3	13.9	BH-236-F01T-0055D-7310	C
		240	3	12.1	BH-236-F01T-0055K-7311	C
		480	3	8.1	BH-236-F01T-0055U-7312	C
		600	3	4.9	BH-236-F01T-0055Z-7313	C
T2 572 (300)	7	208	1	33.7	BH-236-F01T-0072C-7314	C
		240	1	29.2	BH-236-F01T-0072J-7315	C
		480	1	14.6	BH-236-F01T-0072T-7316	C
		208	3	19.5	BH-236-F01T-0072D-7317	C
		240	3	16.9	BH-236-F01T-0072K-7318	C
		480	3	8.5	BH-236-F01T-0072U-7319	C
		600	3	6.8	BH-236-F01T-0072Z-7320	C
T1 842 (450)	10	240	1	41.7	BH-236-F01T-0101J-7321	C
		480	1	20.9	BH-236-F01T-0101T-7322	C
		208	3	27.8	BH-236-F01T-0101D-7323	C
		240	3	24.1	BH-236-F01T-0101K-7324	C
		480	3	12.1	BH-236-F01T-0101U-7325	C
		600	3	9.7	BH-236-F01T-0101Z-7326	C
T1 842 (450)	12	480	1	25.0	BH-236-F01T-0121T-7327	C
		240	3	29.0	BH-236-F01T-0121K-7328	C
		480	3	14.5	BH-236-F01T-0121U-7329	C
		600	3	11.6	BH-236-F01T-0121Z-7330	C

(1) The amps shown are for the heating elements only. The 120V, 1 Ph 60 Hz motor draws 3.8 amps and requires a separate 120V power supply.

(2) Availability Code: C = Custom

Accessory Remote Thermostat

Catalog Number	Switch Type	Description	Type	Ratings	Temp. Range °F (°C)	Availability Code
1007002	Bimetal	Class I, Div. 1, Groups C & D Class II, Div. 1, Groups E, F, & G	SPDT	125-277V, 22A	50-90 (10-32)	AS
1024754	Bulb and Capillary with Internal Set Point Adjustment	Class I, Div. 1, Groups B, C & D Class II, Div. 1, Groups E, F, & G	SPDT	120-240V, 25A 277V, 22A	40-120 (5-49)	
1025396	Bulb and Capillary with Internal Set Point Adjust- ment	Corrosion-Resistant Class I, Div. 1, Groups B, C, & D Class II, Div. 1, Groups E, F & G	SPST	120-240V, 25A 277V, 22A	40-120 (5-49)	

254 Series CONVECTOR

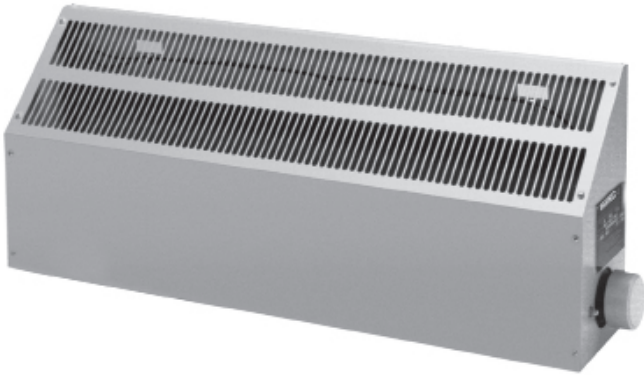

Class I, Divisions 1 and 2, Groups B, C and D
Class II, Divisions 1 and 2, Groups E, F and G
Class I, Zones 1 and 2, Groups IIB and H2

Applications

- Battery Storage Areas
- Chemical Plants
- Coal Handling Facilities
- Dry Cleaning Plants
- Gasoline Fueling/Storage Areas
- Grain Elevators
- Oil Refineries
- Paint Spraying/Storage Areas
- Petrochemical Plants

Brasch's explosion-proof 254 Series Convector is designed to provide a heavy duty and corrosion resistant heat source. Features include:

- Wide Selection of Sizes: Four compact sizes to fit any space with ratings from 500 to 9,500 watts.
- Sloped Top Cabinet: Prevents objects from being set on top of the convector, which can restrict airflow and cause overheating.
- Single and Three-Phase: Unique design provides single and balanced three-phase loads in a single element.
- Gas and Dust Atmospheres: Three listings cover the entire field, two for hazardous gases and vapors and one for dust particles.
- Wet Locations: All unit sizes available with iridite-coated elements and powder-coated frames for NEMA 3 wet locations.

Standard Construction Features

Element – Grade A Nickel-Chromium heating coils are insulated with ceramics and magnesium oxide from the copper heater tube and fitted with large aluminum fins locked in place.

Cabinet – Heavy gauge galvanized steel cabinet is painted with a beige powder coat for durability. Cabinet should be mounted at least 6 inches (152 mm) above the floor. Factory-furnished wall brackets make installation easy.

Thermal Protection – A linear limit, automatic reset thermal cutout is built into every unit.

Complete Electrical Package – For larger single-phase and all three-phase units, a built-on contactor and transformer option package are available.

Electrical Package Options

All single-phase heaters rated over 22 amps or 277 volts and all three-phase heaters require a magnetic contactor. Some electrical combinations will also require a control transformer.

To simplify field installation, these accessories are factory-mounted on the heater cabinet and factory pre-wired (not available on Size 1 convectors).

Code	Option	Description	Availability Code (2)
B2	Electric Control Option (1) (without thermostat)	Classes I and II, Groups B, C, E, D, F and G includes contactor and transformer (as required). Required for all three-phase and single-phase heaters over 22 amps or 277 volts	AS
B2S1	Thermostat & Controls (1)	Classes I and II, Groups C, D, E, F and G includes thermostat, contactor and transformer (as required).	AS
B3	Thermostat & Controls (Group B) (1)	Classes I and II, Groups B, C, D, E, F and G includes thermostat, contactor and transformer (as required). Thermostat has internal set point.	AS
S1	Thermostat Only (1)	Classes I and II, Groups C, D, E, F and G single-phase heaters rated up to 22 amps at 120-277 volts. Use remote room thermostat Catalog Number 1007002 for Size 1 convectors.	AS
S2	Thermostat Only (Group B) (1)	Classes I and II, Groups B, C, D, E, F and G single-phase heaters rated up to 22 amps at 120-277 volts. Thermostat has internal set point. Use remote room thermostat Catalog Number 1024754 for Size 1 convectors.	AS

(1) These options are not available on Size 1 Convectors.

Custom Option

Code	Option	Description	Availability Code (2)
C1	Wet Locations	Type 3 rated construction. Includes Iridite coated element assembly and gasketed terminal box. Not available with options B2/S1, S1, or S2.	C
C2	Corrosive-Resistant Stainless Steel Construction	Type 3 rated construction with addition of stainless steel cabinet. Includes Iridite coated element assembly and gasketed terminal box. Not available with options B2/S1, S1, or S2. ONLY the cabinet is upgraded to stainless steel.	C

(2) AS = Assembly Stock, C = Custom. Assembly Stock heaters ordered with custom options are subject to longer delivery.

Accessory Remote Thermostat

Catalog Number	Switch Type	Description	Type	Ratings	Temp. Range °F (°C)	Availability Code
1007002	Bimetal	Class 1, Div. 1, Groups C & D Class II, Div. 1, Groups E, F, & G	SPDT	125-277V, 22A	50-90 (10-32)	AS
BH-1024754	Bulb and Capillary with Internal Set Point Adjustment	Class 1, Div. 1, Groups B, C & D Class II, Div. 1, Groups E, F, & G	SPDT	120-240V, 25A 277V, 22A	40-120 (5-49)	
BH-1025396	Bulb and Capillary with Internal Set Point Adjustment	Corrosion-Resistant Class 1, Div. 1, Groups B, C, & D Class II, Div. 1, Groups E, F & G	SPST	120-240V, 25A 277V, 22A	40-120 (5-49)	

254 Series

CONVECTOR

Class I, Divisions 1 & 2, Groups B, C & D
Ignition Temperature Code T2A, 536°F (280°C)
Class I, Zones 1 and 2 Groups IIB + H2

Use these heaters when ordering heaters without optional built-on controls

KW	Volts (1)	Phase	Total Amps	Unit Size	Catalog Number	Availability Code (3)	Optional Built-on Controls	
							Controls Only	Thermostat Only (3) or Thermostat with Controls
0.5	120	1	4.2	1	BH-254-F0310052B	AS	N/A	1024754
	208	1	2.4		BH-254-F0310052C		N/A	1024754
	240	1	2.1		BH-254-F0310052J		N/A	1024754
	277	1	1.8		BH-254-F0310052N		N/A	1024754
1	120	1	8.3	1	BH-254-F0310102B		N/A	1024754
	208	1	4.8		BH-254-F0310102C		N/A	1024754
	240	1	4.2		BH-254-F0310102J		N/A	1024754
	277	1	3.6		BH-254-F0310102N		N/A	1024754
1.8	120	1	15.0	2	BH-254-F0320182B		N/R	S2
	208	1	8.7		BH-254-F0320182C		N/R	S2
	240	1	7.5		BH-254-F0320182J		N/R	S2
	277	1	6.5		BH-254-F0320182N		N/R	S2
	347	1	5.2		BH-254-F0320182I		B2	B3
	480	3	2.2		BH-254-F0320182U		B2	B3
2.5	600	3	1.8	2	BH-254-F0320182Z		B2	B3
	208	1	12.0		BH-254-F0320252C		N/R	S2
	208	3	6.9		BH-254-F0320252D	B2	B3	
	240	1	10.4		BH-254-F0320252J	N/R	S2	
	277	1	9.0		BH-254-F0320252N	N/R	S2	
	347	1	7.2		BH-254-F0320252I	B2	B3	
3.6	480	3	3.0	3	BH-254-F0320252U	B2	B3	
	600	3	2.4		BH-254-F0320252Z	B2	B3	
	208	1	17.3		BH-254-F0330362C	N/R	S2	
	208	3	10.0		BH-254-F0330362D	B2	B3	
	240	1	15.0		BH-254-F0330362J	N/R	S2	
	277	1	13.0		BH-254-F0330362N	N/R	S2	
4.4	347	1	10.4	3	BH-254-F0330362I	B2	B3	
	480	3	4.3		BH-254-F0330362U	B2	B3	
	600	3	3.5		BH-254-F0330362Z	B2	B3	
	208	3	12.2		BH-254-F0330442D	B2	B3	
	240	1	18.3		BH-254-F0330442J	N/R	S2	
	277	1	15.9		BH-254-F0330442N	N/R	S2	
6.5	347	1	12.7	4	BH-254-F0330442I	B2	B3	
	480	3	5.3		BH-254-F0330442U	B2	B3	
	600	3	4.3		BH-254-F0330442Z	B2	B3	
	208	3	18.0		BH-254-F0340652D	B2	B3	
	240	3	27.1		BH-254-F0340652J	B2	B3	
	277	1	23.5		BH-254-F0340652N	B2	B3	
7.5	347	1	18.7	4	BH-254-F0340652I	B2	B3	
	480	3	7.8		BH-254-F0340652U	B2	B3	
	600	3	6.3		BH-254-F0340652Z	B2	B3	
	208	3	20.8		BH-254-F0340752D	B2	B3	
	240	1	31.3		BH-254-F0340752J	B2	B3	
	277	1	27.1		BH-254-F0340752N	B2	B3	
9.5	347	1	21.6	4	BH-254-F0340752I	B2	B3	
	480	3	9.0		BH-254-F0340752U	B2	B3	
	600	3	7.2		BH-254-F0340752Z	B2	B3	
	208	3	26.4		BH-254-F0340952D	B2	B3	
	240	1	39.6		BH-254-F0340952J	B2	B3	
	277	1	34.3		BH-254-F0340952N	B2	B3	
9.5	347	1	27.4	4	BH-254-F0340952I	B2	B3	
	480	3	11.4		BH-254-F0340952U	B2	B3	
	600	3	9.1		BH-254-F0340952Z	B2	B3	

- (1) Conveyors are 60/50 Hz rated
- (2) AS = Assembly Stock, AS listed heaters ordered with custom (C) features are subject to longer lead times.
- (3) Thermostat only is load carrying or remote.

254 Series CONVECTOR

Class I, Divisions 1 & 2, Groups C & D
Class I, Zones 1 and 2 Groups IIB
Ignition Temperature Code T2A, 536°F (280°C)

KW	Volts (1)	3Phase	Total Amps	Unit Size	Catalog Number	Availability Code (3)	Optional Built-on Controls	
							Controls Only	Thermostat Only (3) or Thermostat with Controls
0.5	120	1	4.2	1	BH-254-F0310053B	AS	N/A	1007002
	208	1	2.4		BH-254-F0310053C		N/A	1007002
	240	1	2.1		BH-254-F0310053J		N/A	1007002
	277	1	1.8		BH-254-F0310053N		N/A	1007002
1	120	1	8.3	1	BH-254-F0310103B		N/A	1007002
	208	1	4.8		BH-254-F0310103C		N/A	1007002
	240	1	4.2		BH-254-F0310103J		N/A	1007002
	277	1	3.6		BH-254-F0310103N		N/A	1007002
1.8	120	1	15.0	2	BH-254-F0320183B		N/R	S1
	208	1	8.7		BH-254-F0320183C		N/R	S1
	240	1	7.5		BH-254-F0320183J		N/R	S1
	277	1	6.5		BH-254-F0320183N		N/R	S1
	347	1	5.2		BH-254-F0320183I		B2	B2S1
	480	3	2.2		BH-254-F0320183U		B2	B2S1
2.5	600	3	1.8	2	BH-254-F0320183Z		B2	B2S1
	208	1	12.0		BH-254-F0320253C		N/R	S1
	208	3	6.9		BH-254-F0320253D		B2	B2S1
	240	1	10.4		BH-254-F0320253J		N/R	S1
	277	1	9.0		BH-254-F0320253N		N/R	S1
	347	1	7.2		BH-254-F0320253I		B2	B2S1
3.6	480	3	3.0	2	BH-254-F0320253U	B2	B2S1	
	600	3	2.4		BH-254-F0320253Z	B2	B2S1	
	208	1	17.3		BH-254-F0330363C	N/R	S1	
	208	3	10.0		BH-254-F0330363D	B2	B2S1	
	240	1	15.0		BH-254-F0330363J	N/R	S1	
	277	1	13.0		BH-254-F0330363N	N/R	S1	
4.4	347	1	10.4	3	BH-254-F0330363I	B3	B3S1	
	480	3	4.3		BH-254-F0330363U	B2	B2S1	
	600	3	3.5		BH-254-F0330363Z	B2	B2S1	
	208	3	12.2		BH-254-F0330443D	B2	B2S1	
	240	1	18.3		BH-254-F0330443J	N/R	S1	
	277	1	15.9		BH-254-F0330443N	N/R	S1	
6.5	347	1	12.7	3	BH-254-F0330443I	B2	B3S1	
	480	3	5.3		BH-254-F0330443U	B2	B2S1	
	600	3	4.3		BH-254-F0330443Z	B2	B2S1	
	208	3	18.0		BH-254-F0340653D	B2	B2S1	
	240	1	27.1		BH-254-F0340653J	B2	B2S1	
	277	1	23.5		BH-254-F0340653N	B2	B2S1	
7.5	347	1	18.7	4	BH-254-F0340653I	B2	B2S1	
	480	3	7.8		BH-254-F0340653U	B2	B2S1	
	600	3	6.3		BH-254-F0340653Z	B2	B2S1	
	208	3	20.8		BH-254-F0340753D	B2	B2S1	
	240	1	31.3		BH-254-F0340753J	B2	B2S1	
	277	1	27.1		BH-254-F0340753N	B2	B2S1	
9.5	347	1	21.6	4	BH-254-F0340753I	B2	B2S1	
	480	3	9.0		BH-254-F0340753U	B2	B2S1	
	600	3	7.2		BH-254-F0340753Z	B2	B2S1	
	208	3	26.4		BH-254-F0340953D	B2	B2S1	
	240	1	39.6		BH-254-F0340953J	B2	B2S1	
	277	1	34.3		BH-254-F0340953N	B2	B2S1	
9.5	347	1	27.4	4	BH-254-F0340953I	B2	B2S1	
	480	3	11.4		BH-254-F0340953U	B2	B2S1	
	600	3	9.1		BH-254-F0340953Z	B2	B2S1	

(1) Convector are 60/50 Hz rated

(2) AS = Assembly Stock, AS listed heaters ordered with custom (C) features are subject to longer lead times.

(3) Thermostat only is load carrying or remote.

254 Series

CONVECTOR

Class I, Divisions 1 & 2, Groups B, C & D
Ignition Temperature Code T3A, 356°F (180°C)
Class I, Zones 1 and 2 Groups IIB + H2

Use these heaters when ordering heaters without optional built-on controls

KW	Volts (1)	Phase	Total Amps	Unit Size	Catalog Number	Availability Code (3)	Optional Built-on Controls	
							Controls Only	Thermostat Only (3) or Thermostat with Controls
0.5	120	1	4.2	1	BH-254-F0610052B	AS	N/A	1024754
	208	1	2.4		BH-254-F0610052C		N/A	1024754
	240	1	2.1		BH-254-F0610052J		N/A	1024754
	277	1	1.8		BH-254-F0610052N		N/A	1024754
1.4	120	1	11.7	2	BH-254-F0620142B		N/R	S2
	208	1	6.7		BH-254-F0620142C		N/R	S2
	240	1	5.8		BH-254-F0620142J		N/R	S2
	277	1	5.1		BH-254-F0620142N		N/R	S2
	347	1	4.0		BH-254-F0620142I		B2	B3
2.3	120	1	19.2	3	BH-254-F0630232B		N/R	S2
	208	1	11.1		BH-254-F0630232C		N/R	S2
	208	3	6.4		BH-254-F0630232D		B2	B3
	240	1	9.6		BH-254-F0630232J		N/R	S2
	277	1	8.3		BH-254-F0630232N		N/R	S2
	347	1	6.6		BH-254-F0630232I		B2	B3
	480	3	2.8		BH-254-F0630232U		B2	B3
	600	3	2.2		BH-254-F0630232Z		B2	B3
3.2	208	1	15.4	4	BH-254-F0640322C		N/R	S2
	208	3	8.9		BH-254-F0640322D		B2	B3
	240	1	13.3		BH-254-F0640322J		N/R	S2
	277	1	11.6		BH-254-F0640322N		N/R	S2
	347	1	9.2		BH-254-F0640322I		B2	B3
	480	3	3.8		BH-254-F0640322U		B2	B3
	600	3	3.1		BH-254-F0640322Z		B2	B3
5.0	208	3	13.9	4	BH-254-F0640502D		B2	B3
	240	1	20.8		BH-254-F0640502J		N/R	S2
	277	1	18.1		BH-254-F0640502N		N/R	S2
	347	1	14.4		BH-254-F0640502I		B2	B3
	480	3	6.0		BH-254-F0640502U		B2	B3
	600	3	4.8		BH-254-F0640502Z		B2	B3

(1) Convector are 60/50 Hz rated

(2) AS = Assembly Stock, AS listed heaters ordered with custom (C) features are subject to longer lead times.

(3) Thermostat only is load carrying or remote.

254 Series CONVECTOR

Class I, Divisions 1 & 2, Groups C & D
Class I, Zones 1 and 2 Groups IIB
Ignition Temperature Code T3A, 356°F (180°C)

KW	Volts (1)	Phase	Total Amps	Unit Size	Catalog Number	Availability Code (3)	Optional Built-on Controls	
							Controls Only	Thermostat Only (3) or Thermostat with Controls
0.5	120	1	4.2	1	BH-254-F0610053B	AS	N/A	1007002
	208	1	2.4		BH-254-F0610053C		N/A	1007002
	240	1	2.1		BH-254-F0610053J		N/A	1007002
	277	1	1.8		BH-254-F0610053N		N/A	1007002
1.4	120	1	11.7	2	BH-254-F0620143B		N/R	S1
	208	1	6.7		BH-254-F0620143C		N/R	S1
	240	1	5.8		BH-254-F0620143J		N/R	S1
	277	1	5.1		BH-254-F0620143N		N/R	S1
	347	1	4.0		BH-254-F0620143I		B2	B2S1
2.3	120	1	19.2	3	BH-254-F0630233B		N/R	S1
	208	1	11.1		BH-254-F0630233C		N/R	S1
	208	3	6.4		BH-254-F0630233D		B2	B2S1
	240	1	9.6		BH-254-F0630233J		N/R	S1
	277	1	8.3		BH-254-F0630233N		N/R	S1
	347	1	6.6		BH-254-F0630233I		B2	B2S1
	480	3	2.8		BH-254-F0630233U		B2	B2S1
	600	3	2.2		BH-254-F0630233Z		B2	B2S1
3.2	208	1	15.4	4	BH-254-F0640323C		N/R	S1
	208	3	8.9		BH-254-F0640323D		B2	B2S1
	240	1	13.3		BH-254-F0640323J		N/R	S1
	277	1	11.6		BH-254-F0640323N		N/R	S1
	347	1	9.2		BH-254-F0640323I		B2	B2S1
	480	3	3.8		BH-254-F0640323U		B2	B2S1
	600	3	3.1		BH-254-F0640323Z		B2	B2S1
5.0	208	3	13.9	4	BH-254-F0640503D		B2	B2S1
	240	1	20.8		BH-254-F0640503J		N/R	S1
	277	1	18.1		BH-254-F0640503N		N/R	S1
	347	1	14.4		BH-254-F0640503I		B2	B2S1
	480	3	6.0		BH-254-F0640503U		B2	B2S1
	600	3	4.8		BH-254-F0640503Z		B2	B2S1

(1) Convector are 60/50 Hz rated

(2) AS = Assembly Stock, AS listed heaters ordered with custom (C) features are subject to longer lead times.

(3) Thermostat only is load carrying or remote.

254 Series

CONVECTOR

Class I, Divisions 1 & 2, Groups B, C & D
 Class II, Divisions 1 & 2, Groups E, F & G
 Ignition Temperature Code T3C, 320°F (160°C)

KW	Volts (1)	Phase	Total Amps	Unit Size	Catalog Number	Availability Code (3)	Optional Built-on Controls	
							Controls Only	Thermostat Only (3) or Thermostat with Controls
0.5	120	1	4.2	1	BH-254-F0810054B	AS	N/A	1007002
	208	1	2.4		BH-254-F0810054C		N/A	1007002
	240	1	2.1		BH-254-F0810054J		N/A	1007002
	277	1	1.8		BH-254-F0810054N		N/A	1007002
1.0	120	1	8.3	2	BH-254-F0820104B	AS	N/R	S1
	208	1	4.8		BH-254-F0820104C		N/R	S1
	240	1	4.2		BH-254-F0820104J		N/R	S1
	277	1	3.6		BH-254-F0820104N		N/R	S1
	347	1	2.9		BH-254-F0820104I		B2	B2S1
1.7	120	1	14.2	3	BH-254-F0830174B	AS	N/R	S1
	208	1	8.2		BH-254-F0830174C		N/R	S1
	208	3	4.7		BH-254-F0830174D		B2	B2S1
	240	1	7.1		BH-254-F0830174J		N/R	S1
	277	1	6.1		BH-254-F0830174N		N/R	S1
	347	1	4.9		BH-254-F0830174I		B2	B2S1
	480	3	2		BH-254-F0830174U		B2	B2S1
	600	3	1.6		BH-254-F0830174Z		B2	B2S1
3.2	208	1	15.4	4	BH-254-F0840324C	AS	N/R	S1
	208	3	8.9		BH-254-F0840324D		B2	B2S1
	240	1	13.3		BH-254-F0840324J		N/R	S1
	277	1	11.6		BH-254-F0840324N		N/R	S1
	347	1	9.2		BH-254-F0840324I		B2	B2S1
	480	3	3.8		BH-254-F0840324U		B2	B2S1
	600	3	3.1		BH-254-F0840324Z		B2	B2S1

(1) Conectors are 60/50 Hz rated

(2) AS = Assembly Stock, AS listed heaters ordered with custom (C) features are subject to longer lead times.

(3) Thermostat only is load carrying or remote.

Accessory Remote Thermostat

Catalog Number	Switch Type	Description	Type	Ratings	Temp. Range °F (°C)	Availability Code
1007002	Bimetal	Class I, Div. 1, Groups C & D Class II, Div. 1, Groups E, F, & G	SPDT	125-277V, 22A	50-90 (10-32)	AS
1024754	Bulb and Capillary with Internal Set Point Adjustment	Class I, Div. 1, Groups B, C & D Class II, Div. 1, Groups E, F, & G	SPDT	120-240V, 25A 277V, 22A	40-120 (5-49)	
1025396	Bulb and Capillary with Internal Set Point Adjustment	Corrosion-Resistant Class I, Div. 1, Groups B, C, & D Class II, Div. 1, Groups E, F & G	SPST	120-240V, 25A 277V, 22A	40-120 (5-49)	

254 Series CONVECTOR

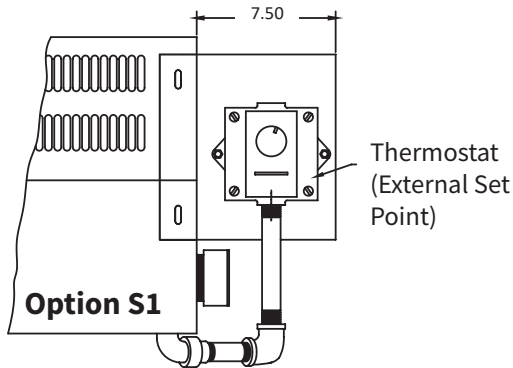

Thermostat is rated for Class I, Groups C and D
Class II Groups E, F and G

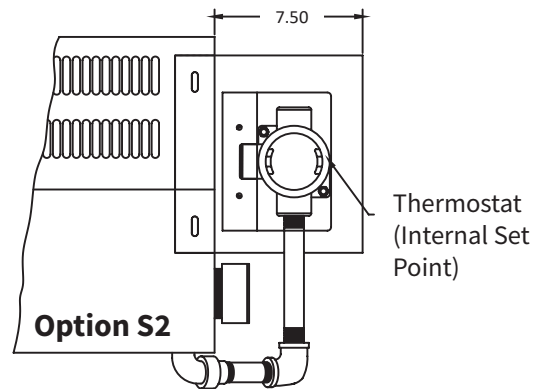

Thermostat is rated for Class I, Groups B, C and D
Class II Groups E, F and G

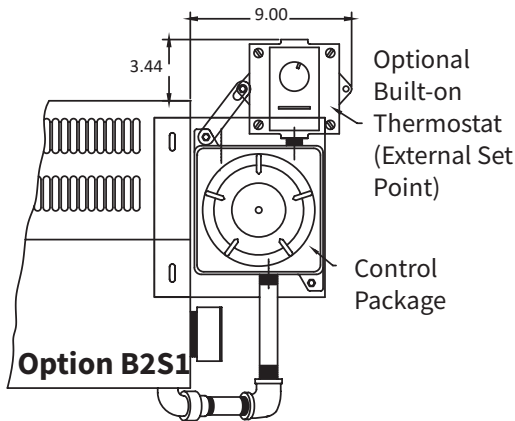

Thermostat is rated for Class I, Groups C and D
Class II Groups E, F and G

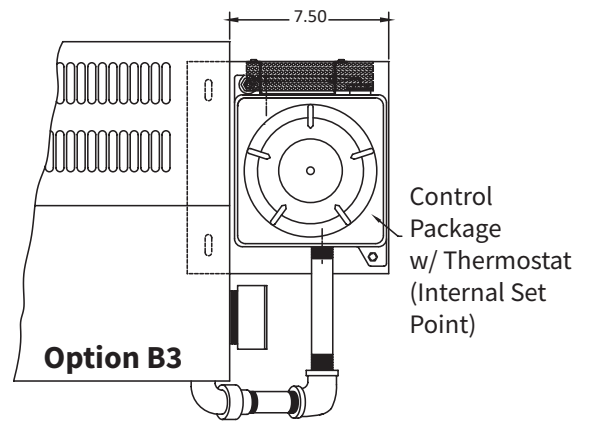

Thermostat is rated for Class I, Groups B, C and D
Class II Groups E, F and G

Dimensions and Weights

Unit Size	Dimensions - In. (cm)			Weight - Lb (kg)
	Length (L)	Height (H)	Depth (D)	Without Controls
1	26 (66)	6 (15)	4-1/2 (11)	13 (5.9)
2	26 (66)	16 (41)	8 (20)	27 (12.2)
3	39 (99)	16 (41)	8 (20)	36 (16.3)
4	67-1/2 (171)	16 (41)	8 (20)	60 (27.2)

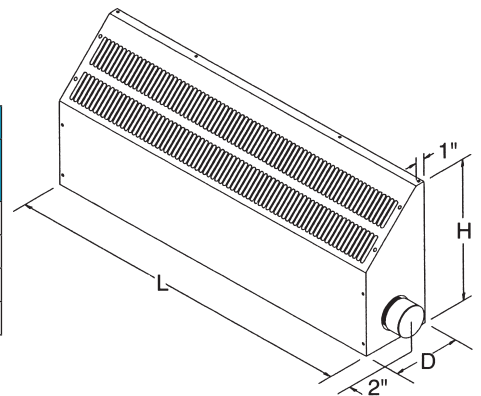

Comparison Chart

234 Series



238 Series



BTUR 240 Series



Features	Washdown 234 Series	238 Series	BTUR 240 Series
Typical Applications	Food processing plants Marine duty Wastewater treatment plants	Factories Warehouses	Factories Mechanical rooms Workshops
KW Range	2 to 47	3 to 38.4	3.3 to 50
Voltages	up to 600/3	Up to 480/3	Up to 600/3
Airflow CFM	Up to 2400	Up to 1774	Up to 3100
Discharge	Horizontal	Horizontal	Horizontal or Vertical
Element Type	Stainless steel finned tubular	Stainless steel finned tubular	Stainless steel finned tubular
Standard Construction	16 gauge stainless steel shroud and non-metallic NEMA 4X control enclosure	16 gauge galvanized steel shroud and control enclosure	20-14 gauge (depending on size) galvanized steel cabinet
Finish	Stainless steel	Beige polyester powder paint	Camel polyester powder paint
Mounting	Ceiling or wall	Ceiling or wall	Ceiling or wall
Agency Approvals	UL _{c-us}	UL _{c-us}	UL _{c-us}

234 Series

WASHDOWN/CORROSION RESISTANT UNIT HEATER



The Brasch 234 Series unit heater is the perfect solution to the problem of heating people or equipment in non-hazardous environments where moisture and corrosion exist. Advantages of the 234 Series include:

- **Built-in Controls:** All necessary safety and temperature controls are included in a single package. Components and motor are factory-wired to a single terminal block for field wiring, eliminating the chance for field error and reducing installation costs.
- **Single Point Electrical Hook-up:** Heater, fan motor and controls are all connected to the same branch circuit.
- **Corrosion Resistant:** Stainless steel construction, powder-coated aluminum fan blade and nonmetallic NEMA 4X terminal enclosure resist corrosion found in sewage treatment plants, swimming pool areas, car washes, paper mills and marine installations.
- **Washable:** This watertight construction can be hosed down without disconnecting the heater, which makes it ideal for coal handling areas, steel mills, foundries, ships, wood finishing plants, cement, sand, grain and food processing facilities.

Applications

- Car Washes
- Cement Plants
- Coal Handling Areas
- Dairies
- Food Processing Plants
- Marine and Offshore
- Power Generating Stations
- Steel Mills and Foundries
- Swimming Pool Areas
- Wastewater Treatment Plants

Standard Construction Features

Heating Elements – Industrial grade, Type 316 stainless steel tubular elements with stainless steel fins, manufactured by Brasch.

Fan Motor Assembly – Totally enclosed, epoxy coated, UL Recognized motor with permanently lubricated ball bearings for longer life. Designed to resist moisture and corrosion. Factory-wired to NEMA 4X enclosure. Fitted with a powder-coated, aluminum fan blade suitable for corrosive salt spray environments.

Housing – Heating elements and motor are enclosed in a round, heavy 16-gauge 304 stainless steel shroud.

Inlet/Outlet Grilles – Adjustable, stainless steel, louvered outlet grille can be rotated 90° to direct airflow up, down, left or right. Heavy gauge, 304 stainless steel rear grille protects against accidental contact with the fan blade.

Control Enclosure – The non-metallic enclosure, which houses the element terminals and built-in controls, will not rust and meets NEMA 4X hose-down requirements.

Built-in Controls – Include automatic reset overtemperature cutout, fan delay relay, controlling contactor, transformer for 24-volt control circuit, terminal block for field wiring and a separate motor contactor (when required).

Mounting Bracket – The heater comes complete with a 304 stainless steel swivel mounting bracket which can be used either for wall or ceiling mounting. Four field-supplied 3/8-16 threaded rods can also be used for ceiling installation.

234 Series

WASHDOWN/CORROSION RESISTANT UNIT HEATER

Factory Built-in Options

Code	Description	Availability Code (2)
B	Delete swivel mounting bracket. Heater installs from the ceiling with field furnished threaded rods.	AS
C	Epoxy painted stainless steel parts: housing and grilles.	C
D	Power disconnect switch	AS
E	Monel finned tubular elements	C
F8	Fan motor fusing with disconnecting contactor	C
L	"Heater on" pilot light	AS
M	Secondary manual reset overtemperature cutout.	AS
S	Three-position selector switch (heater-standby-fan)	AS
T	1- Stage Built-in thermostat 40 to 100° F (5 to 38° C) range	AS
	2- Stage Built-in thermostat 40 to 120° F (5 to 49° C) range (Option "X" required)	C
V	120 volt control circuit	AS
X	2-Stage Control	C

(2) AS = Assembly Stock, C = Custom. Assembly Stock heaters ordered with custom options are subject to longer delivery.

Dimensions, Airflow and Weights

Dimensions, Airflows and Weights		KW		
		2 - 7.5	9 - 12	12.5 - 47
Overall Heater Dimensions	"X" Inch (cm)	15-1/2 (39)	15-1/2 (39)	24-1/2 (66)
	"Y" Inch (cm)	21-1/2 (55)	21-1/2 (55)	26 (71)
	"Z" Inch (cm)	13 (33)	13 (33)	20 (51)
Mounting Hole Dimensions	"BH" Inch (cm)	4-1/4 (11)	4-1/4 (11)	7-1/8 (18)
	"BL" Inch (cm)	19-1/2 (50)	19-1/2 (50)	22-1/4 (57)
	"M" Inch (cm)	8-1/2 (22)	8-1/2 (22)	5 (8)
Airflow Characteristics	Air Volume CFM (cubic meters/hr)	700 (1189)	1450 (2463)	2400 (4077)
	Air Throw Feet (m)	26 (8)	43 (13)	50 (15)
	Outlet Velocity FPM (meters/min)	760 (232)	1575 (481)	1200 (366)
Weight	Net Lbs (kgs)	56 (25)	56 (25)	115 (52)
	Shipping Lbs (kgs)	70 (32)	70 (32)	130 (60)

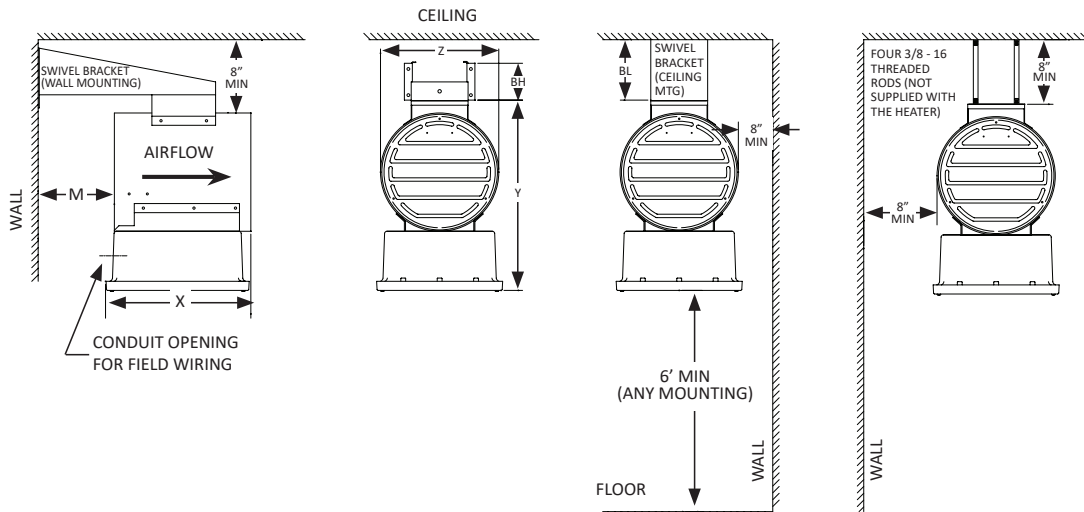

234 Series

WASHDOWN/CORROSION RESISTANT UNIT HEATER

Remote Room Thermostat

Catalog Number	Switch Type	Ratings	Type	Tamper-proof	Thermo-meter	Amps	Pilot Duty	Temperature Range °F (°C)
1004328	Bulb	NEMA 4X	SPDT	No	No	25A @ 120-240V 22A @ 277V	125VA	40-110 (5-43)
1026347	2-Stage Bulb	NEMA 4X	2 SPDT	No	No	25A @ 120-240V 22A @ 277V	125VA	40-100 (5-38)



1004328



1026347

234 Series Unit Heater Listing

For Non-Hazardous Areas

KW	Volts	Ph	Total Amps (1)	Approximate Air Temperature Rise °F (°C)	Motor			Catalog Number	2-Stage Control	Availability Code (2)(3)
					HP	Volts	Ph			
2	120	1	21	9 (5)	1/4	120	1	BH-234-U11R-0020B	1B	AS
	208	1	12	9 (5)	1/4	208	1	BH-234-U11R-0020C	1B	
	240	1	11	9 (5)	1/4	240	1	BH-234-U11R-0020J	1B	
	277	1	10	9 (5)	1/4	277	1	BH-234-U11R-0020N	1B	
	347	1	7	9 (5)	1/4	347	1	BH-234-U11R-0020I	1B	
3	120	1	29	14 (8)	1/4	120	1	BH-234-U11N-0030B	1A	
	208	1	17	14 (8)	1/4	208	1	BH-234-U11N-0030C	1A	
	240	1	15	14 (8)	1/4	240	1	BH-234-U11N-0030J	1A	
	277	1	13	14 (8)	1/4	277	1	BH-234-U11N-0030N	1A	
	347	1	11	14 (8)	1/4	347	1	BH-234-U11N-0030I	1A	
	480	1	8	14 (8)	1/4	480	1	BH-234-U11N-0030T	1A	
	208	3	11	14 (8)	1/4	208	1	BH-234-U11N-0030D	1A	
	240	3	10	14 (8)	1/4	240	1	BH-234-U11N-0030K	1A	
	480	3	5	14 (8)	1/4	480	1	BH-234-U11N-0030U	1A	
600	3	4	14 (8)	1/4	600	1	BH-234-U11N-0030Z	1A		
5	208	1	27	24 (13)	1/4	208	1	BH-234-U11R-0050C	1B	
	240	1	23	24 (13)	1/4	240	1	BH-234-U11R-0050J	1B	
	277	1	20	24 (13)	1/4	277	1	BH-234-U11R-0050N	1B	
	347	1	17	24 (13)	1/4	347	1	BH-234-U11R-0050I	1B	
	480	1	12	24 (13)	1/4	480	1	BH-234-U11R-0050T	1B	
	208	3	16	24 (13)	1/4	208	1	BH-234-U11N-0050D	1A	
	240	3	15	24 (13)	1/4	240	1	BH-234-U11N-0050K	1A	
	480	3	8	24 (13)	1/4	480	1	BH-234-U11N-0050U	1A	
600	3	6	24 (13)	1/4	600	1	BH-234-U11N-0050Z	1A		
7.5	208	1	39	35 (19)	1/4	208	1	BH-234-U11N-0080C	1A	
	240	1	34	35 (19)	1/4	240	1	BH-234-U11N-0080J	1A	
	277	1	29	35 (19)	1/4	277	1	BH-234-U11N-0080N	1A	
	347	1	24	35 (19)	1/4	347	1	BH-234-U11N-0080I	1A	
	480	1	17	35 (19)	1/4	480	1	BH-234-U11N-0080T	1A	
	208	3	23	35 (19)	1/4	208	1	BH-234-U11N-0080D	1A	
	240	3	21	35 (19)	1/4	240	1	BH-234-U11N-0080K	1A	
	480	3	11	35 (19)	1/4	480	1	BH-234-U11N-0080U	1A	
	600	3	9	35 (19)	1/4	600	1	BH-234-U11N-0080Z	1A	

(1) Total Amps = Heating element amps and motor amps.
 (2) Availability Code: AS = Assembly Stock,
 (3) Stock heaters ordered with custom options subject to longer delivery.

NOTE: 2-Stage heaters can be field wired as single stage. 1A = Optional 2-stage control, unbalanced (option 'X'). 1B = Optional 2-stage control, balanced (option 'X')

234 Series

WASHDOWN/CORROSION RESISTANT UNIT HEATER

234 Series Unit Heater Listing (continued) For Non-Hazardous Areas

KW	Volts	Ph	Total Amps (1)	Approximate Air Temperature Rise °F (°C)	Motor			Catalog Number	2-Stage Control	Availability Code (2)(3)
					HP	Volts	Ph			
9	208	1	46	20 (11)	1/4	208	1	BH-234-U11N-0090C	1A	AS
	240	1	40	20 (11)	1/4	240	1	BH-234-U11N-0090J	1A	
	277	1	35	20 (11)	1/4	277	1	BH-234-U11N-0090N	1A	
	347	1	29	20 (11)	1/4	347	1	BH-234-U11N-0090I	1A	
	480	1	20	20 (11)	1/4	480	1	BH-234-U11N-0090T	1A	
	208	3	28	20 (11)	1/4	208	1	BH-234-U11N-0090D	1A	
	240	3	24	20 (11)	1/4	240	1	BH-234-U11N-0090K	1A	
	480	3	12	20 (11)	1/4	480	1	BH-234-U11N-0090U	1A	
600	3	10	20 (11)	1/4	600	1	BH-234-U11N-0090Z	1A		
10	240	1	44	22 (12)	1/4	240	1	BH-234-U11N-0100J	1A	AS
	277	1	39	22 (12)	1/4	277	1	BH-234-U11N-0100N	1A	
	347	1	32	22 (12)	1/4	347	1	BH-234-U11N-0100I	1A	
	480	1	22	22 (12)	1/4	480	1	BH-234-U11N-0100T	1A	
	208	3	30	22 (12)	1/4	208	1	BH-234-U11N-0100D	1A	
	240	3	27	22 (12)	1/4	240	1	BH-234-U11N-0100K	1A	
	480	3	14	22 (12)	1/4	480	1	BH-234-U11N-0100U	1A	
600	3	11	22 (12)	1/4	600	1	BH-234-U11N-0100Z	1A		
12	277	1	46	26 (14)	1/4	277	1	BH-234-U11N-0120N	1A	AS
	347	1	38	26 (14)	1/4	347	1	BH-234-U11N-0120I	1A	
	480	1	27	26 (14)	1/4	480	1	BH-234-U11N-0120T	1A	
	208	3	36	26 (14)	1/4	208	1	BH-234-U11N-0120D	1A	
	240	3	32	26 (14)	1/4	240	1	BH-234-U11N-0120K	1A	
	480	3	16	26 (14)	1/4	480	1	BH-234-U11N-0120U	1A	
600	3	13	26 (14)	1/4	600	1	BH-234-U11N-0120Z	1A		
12.5	347	1	39	17 (9)	1/4	347	1	BH-234-U11L-0130I	1A	AS
	208	3	37	17 (9)	1/4	208	1	BH-234-U11L-0130D	1A	
	240	3	33	17 (9)	1/4	240	1	BH-234-U11L-0130K	1A	
	480	3	17	17 (9)	1/4	480	1	BH-234-U11L-0130U	1A	
	600	3	14	17 (9)	1/4	600	1	BH-234-U11L-0130Z	1A	
15	347	1	47	21 (12)	1/4	347	1	BH-234-U11L-0150I	1A	AS
	208	3	44	21 (12)	1/4	208	1	BH-234-U11L-0150D	1A	
	240	3	39	21 (12)	1/4	240	1	BH-234-U11L-0150K	1A	
	480	3	20	21 (12)	1/4	480	1	BH-234-U11L-0150U	1A	
	600	3	16	21 (12)	1/4	600	1	BH-234-U11L-0150Z	1A	
20	480	3	26	28 (16)	1/4	480	1	BH-234-U11L-0200U	1A	AS
	600	3	21	28 (16)	1/4	600	1	BH-234-U11L-0200Z	1A	
25	480	3	32	35 (19)	1/4	480	1	BH-234-U11A-0250U	1B	AS
	600	3	26	35 (19)	1/4	600	1	BH-234-U11A-0250Z	1B	
30	480	3	38	42 (23)	1/4	480	1	BH-234-U11A-0300U	1B	AS
	600	3	31	42 (23)	1/4	600	1	BH-234-U11A-0300Z	1B	
35	480	3	44	48 (27)	1/4	480	1	BH-234-U11A-0350U	1B	AS
	600	3	35	48 (27)	1/4	600	1	BH-234-U11A-0350Z	1B	
38.4	480	3	48	54 (30)	1/4	480	1	BH-234-U11A-0390U	1B	AS
	600	3	38	54 (30)	1/4	600	1	BH-234-U11A-0390Z	1B	
47	600	3	47	64 (36)	1/4	600	1	BH-234-U11A-0470Z	1B	AS

(1) Total Amps = Heating element amps and motor amps.

(2) Availability Code: AS = Assembly Stock,

(3) Stock heaters ordered with custom options subject to longer delivery.

NOTE: 2-Stage heaters can be field wired as single stage.

1A = Optional 2-stage control, unbalanced (option 'X').

1B = Optional 2-stage control, balanced (option 'X')

238 Series

INDUSTRIAL UNIT HEATER



Applications

- Aircraft Hangars
- Entryways
- Factories
- Garages
- Power Generating Stations
- Pump Houses
- Service Stations

Brasch's 238 Series industrial unit heater is designed for maximum heating performance in non-hazardous and non-corrosive environments. Features include:

- **Unique Design:** Round design of the industrial unit heater provides uniform airflow over the elements to prevent hot spots and ensure even discharge temperatures. Circular stainless steel finned tubular elements have a longer life due to lower operating temperatures.
- **Built-in Controls:** Heaters are completely assembled with all electrical components built-in at the factory to reduce installation costs.
- **Improved Performance:** High CFM's and air throw up to 50 feet promote air circulation within the space. More uniform temperature increases comfort levels and helps to eliminate cold spots.
- **Single Point Electrical Hook-up:** Heater, fan motor and controls are all connected to the same branch circuit.

Standard Construction Features

Heating Elements – Industrial grade, Type 304 stainless steel finned tubular elements, manufactured by Brasch.

Housing – Heating elements and motor are enclosed in a round, 16-gauge galvanized steel enclosure which has a beige powder coat finish for durability.

Inlet/Outlet Grilles – Inlet grille complies with OSHA requirements for fan blade guard. Outlet grille has 45° beige powder coat finish angled louvers to direct airflow.

Fan Motor – Motor is UL Recognized with built-in thermal protection.

Built-in Controls – Include main control magnetic contactor, 24V control voltage transformer, automatic reset thermal cutout and fan thermostat.

Mounting Bracket – Wall mounting bracket with single point suspension allows the heater to rotate a full 360°.

Thermostats

Catalog Number	Switch Type	Color	Type	Tamper-proof	Thermo-meter	Amps @ 120-240V	Amps @ 277V	Pilot Duty	Positive Off	Temperature Range °F
1006998	Bimetal	White	SPDT	No	No	—	—	30VA at 30V max	Yes	50-90

238 Series

INDUSTRIAL UNIT HEATER

Factory Built-in Options

Code	Description	Availability Code (2)
B	No mounting bracket	AS
C	Substitute wall mounting bracket with ceiling bracket (beige powder coat finish for durability)	AS
D	Power Disconnect Switch	AS
G	Adjustable Outlet Louvers (beige powder coat finish for durability)	AS
H	Premium Fan Motor	AS
L	"Heater On" Pilot Light	AS
M	Secondary Manual Reset Thermal Cutout	AS
R	Built-in Fan Relay - Required for Remote Fan Switch	AS
S	Three-position Selector Switch (Heater-Standby-Fan)	AS
T	Built-in Thermostat 40° to 120° F (4° to 49° C) Range	AS
X	No Transformer - Customer supplied control voltage	AS

(2) AS = Assembly Stock, C = Custom. Assembly stock heaters ordered with custom options subject to longer delivery.

Dimensions, Weights and Air Throws

KW	Dimensions - In. (cm)					Weight Lb (kgs)	Maximum Air Throw-Ft. (m)
	M	W	X	Y	Z		
1 - 12	8-1/4 (21)	8-3/4 (22)	15 (38)	17 (43)	13 (41)	45 (20)	15 (5)
12.5 - 20	7 (18)	5-1/2 (14)	16-1/4 (41)	23-1/2 (60)	19-1/4 (49)	60 (27)	50 (15)
25 - 38.4	4 (10)	5-1/2 (14)	20-3/4 (53)	23-1/2 (60)	19-1/4 (49)	80 (36)	50 (15)

*Maximum air throws are based on ideal conditions at time of test at a defined height. Actual performances may vary by installation. Please consult factory for more details

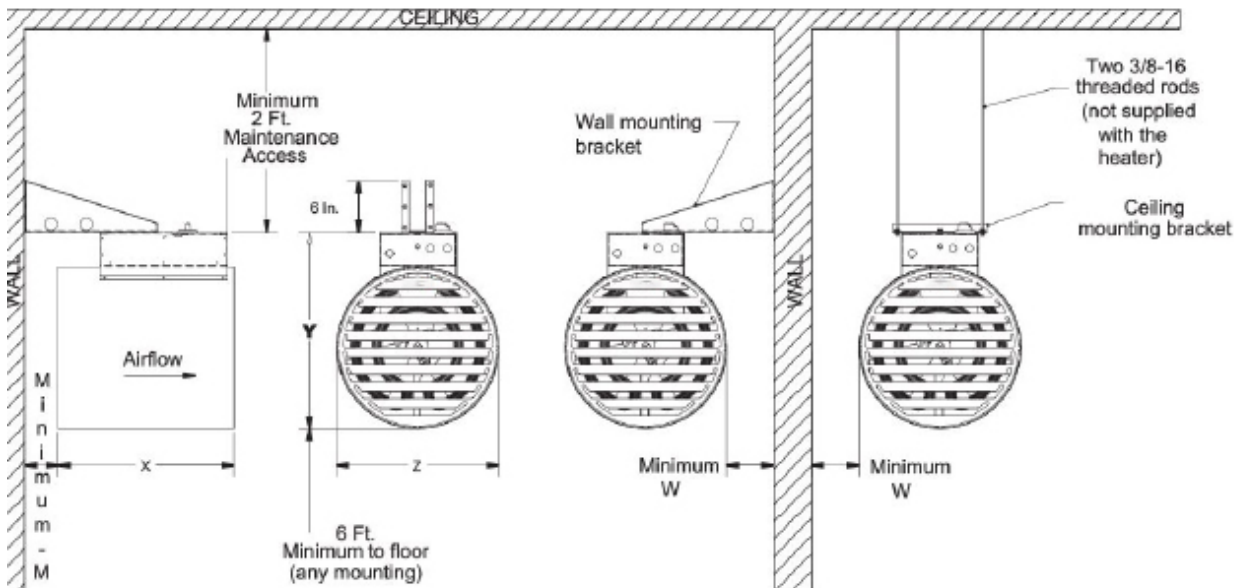

Motor Data

Description	RPM	Airflow - CFM (cubic meters/hr)			Noise Level (dB)		
		3-12 KW	12.5-20 KW	25-38.4 KW	3-12 KW	12.5-20 KW	25-38.4 KW
Standard	1200	362 (615)	1342 (2280)	1237 (2102)	64	68	68
Premium	1800	618 (1050)	1774 (3014)	1635 (2778)	75	84	84

238 Series

INDUSTRIAL UNIT HEATER

Heater Listing

For Non-Hazardous Areas
For Non-Corrosive Areas



KW	Volts	Phase	Total Amps (1)	Approximate Air Temperature Rise °F (°C)	Motor			Catalog Number	Availability Code (2)
					HP	Volts	Phase		
3	120	1	29	15 (8)	1/4	120	1	*BH-238-UR03B	AS
	208	1	17	21 (12)	1/4	208	1	BH-238-UT03C	
	240	1	15	21 (12)	1/4	240	1	BH-238-UT03J	
	277	1	13	15 (8)	1/4	277	1	*BH-238-UR03N	
	347	1	11	15 (8)	1/4	347	1	*BH-238-UR03I	
	480	1	8	21 (12)	1/4	480	1	BH-238-UT03T	
	600	1	6	15 (8)	1/4	600	1	*BH-238-UR03Y	
	208	3	11	21 (12)	1/4	208	1	BH-238-UT03D	
	240	3	10	21 (12)	1/4	240	1	BH-238-UT03K	
480	3	5	21 (12)	1/4	480	1	BH-238-UT03U		
5	208	1	27	35 (19)	1/4	208	1	BH-238-UT05C	
	240	1	23	35 (19)	1/4	240	1	BH-238-UT05J	
	277	1	20	26 (14)	1/4	277	1	*BH-238-UT05N	
	347	1	17	26 (14)	1/4	347	1	*BH-238-UT05I	
	480	1	12	35 (19)	1/4	480	1	BH-238-UT05T	
	600	1	10	26 (14)	1/4	600	1	*BH-238-UT05Y	
	208	3	16	35 (19)	1/4	208	1	BH-238-UT05D	
	240	3	15	35 (19)	1/4	240	1	BH-238-UT05K	
	480	3	8	35 (19)	1/4	480	1	BH-238-UT05U	
600	3	6	26 (14)	1/4	600	1	*BH-238-UT05Z		
7.5	208	1	39	53 (29)	1/4	208	1	BH-238-UT08C	
	240	1	34	53 (29)	1/4	240	1	BH-238-UT08J	
	277	1	29	39 (22)	1/4	277	1	*BH-238-UT08N	
	347	1	24	39 (22)	1/4	347	1	*BH-238-UT08I	
	480	1	17	53 (29)	1/4	480	1	BH-238-UT08T	
	600	1	14	39 (22)	1/4	600	1	*BH-238-UT08Y	
	208	3	23	53 (29)	1/4	208	1	BH-238-UT08D	
	240	3	21	53 (29)	1/4	240	1	BH-238-UT08K	
	480	3	11	53 (29)	1/4	480	1	BH-238-UT08U	
600	3	9	39 (22)	1/4	600	1	*BH-238-UT08Z		
9	208	1	46	64 (36)	1/4	208	1	BH-238-UT09C	
	240	1	40	64 (36)	1/4	240	1	BH-238-UT09J	
	277	1	35	47 (26)	1/4	277	1	*BH-238-UT09N	
	347	1	29	47 (26)	1/4	347	1	*BH-238-UT09I	
	480	1	20	64 (36)	1/4	480	1	BH-238-UT09T	
	600	1	17	47 (26)	1/4	600	1	*BH-238-UT09Y	
	208	3	28	64 (36)	1/4	208	1	BH-238-UT09D	
	240	3	24	64 (36)	1/4	240	1	BH-238-UT09K	
	480	3	12	64 (36)	1/4	480	1	BH-238-UT09U	
600	3	10	47 (26)	1/4	600	1	*BH-238-UT09Z		
10	240	1	44	52 (29)	1/4	240	1	*BH-238-UT10J	
	277	1	39	52 (29)	1/4	277	1	*BH-238-UT10N	
	347	1	32	52 (29)	1/4	347	1	*BH-238-UT10I	
	480	1	22	52 (29)	1/4	480	1	*BH-238-UT10T	
	600	1	19	52 (29)	1/4	600	1	*BH-238-UT10Y	
	208	3	30	52 (29)	1/4	208	1	*BH-238-UT10D	
	240	3	27	52 (29)	1/4	240	1	*BH-238-UT10K	
	480	3	14	52 (29)	1/4	480	1	*BH-238-UT10U	
	600	3	11	52 (29)	1/4	600	1	*BH-238-UT10Z	
12	277	1	46	62 (34)	1/4	277	1	*BH-238-UT12N	
	347	1	38	62 (34)	1/4	347	1	*BH-238-UT12I	
	480	1	27	62 (34)	1/4	480	1	*BH-238-UT12T	
	208	3	36	62 (34)	1/4	208	1	*BH-238-UT12D	
	240	3	32	62 (34)	1/4	240	1	*BH-238-UT12K	
	480	3	16	62 (34)	1/4	480	1	*BH-238-UT12U	
12.5	600	3	13	62 (34)	1/4	600	1	*BH-238-UT12Z	
	347	1	39	22 (12)	1/4	347	1	*BH-238-UL13I	
	208	3	37	31 (17)	1/4	208	1	BH-238-UL13D	
	240	3	33	31 (17)	1/4	240	1	BH-238-UL13K	
	480	3	17	31 (17)	1/4	480	1	BH-238-UL13U	
	600	3	14	22 (12)	1/4	600	1	*BH-238-UL13Z	
15	347	1	47	27 (15)	1/4	347	1	*BH-238-UL15I	
	208	3	44	38 (21)	1/4	208	1	BH-238-UL15D	
	240	3	39	38 (21)	1/4	240	1	BH-238-UL15K	
	480	3	20	38 (21)	1/4	480	1	BH-238-UL15U	
	600	3	16	27 (15)	1/4	600	1	*BH-238-UL15Z	
	20	480	3	26	35 (19)	1/4	480	1	
600		3	21	35 (19)	1/4	600	1	*BH-238-UL20Z	
25	480	3	32	66 (37)	1/4	480	1	BH-238-UA25U	
	600	3	26	44 (24)	1/4	600	1	*BH-238-UA25Z	
30	480	3	38	79 (44)	1/4	480	1	BH-238-UA30U	
	600	3	31	53 (29)	1/4	600	1	*BH-238-UA30Z	
35	480	3	44	61 (34)	1/4	480	1	*BH-238-UA35U	
	600	3	35	61 (34)	1/4	600	1	*BH-238-UA35Z	
38.4	480	3	48	70 (39)	1/4	480	1	*BH-238-UA39U	
	600	3	38	70 (39)	1/4	600	1	*BH-238-UA39Z	

* Premium motor comes standard with heater.

(1) Total Amps = Heating element amps and motor amps.

(2) AS = Assembly Stock, C = Custom. Assembly stock heaters ordered with custom options subject to longer delivery.

240 Series

UNIT HEATER



Shown with optional diffuser



Applications

- Factories
- Garages
- Mechanical Rooms
- Pump Houses
- Service Areas in Air Handling Units
- Shipping and Receiving Areas
- Storage Areas
- Warehouses
- Workshops

The 240 Series unit heater is available in four unit sizes with 59 standard models with ratings up to 50 KW at voltages of 208, 240, 277, 480 and 600 single or three-phase. They are available with a wide variety of factory built-in or field-installed options.

Temperature Control: Single-stage or two-stage control with built-in or remote-mounted thermostats are available on all heaters.

Control Options: Available as factory built-in or field-installed to meet job specifications.

Custom KW's: Custom KW's are available up to 50 KW.

Discharge Direction: The 240 Series heater can be mounted for horizontal or vertical discharge using an optional universal wall/ceiling mounting bracket or with field-furnished threaded rods for ceiling mounting.

Standard Construction Features

Heating Elements - Industrial grade, 0.475" diameter steel sheath with brazed copper plated steel fins and epoxy sealed ends. Draw-thru airflow design pulls air across the heating elements to ensure cool element operation and even air distribution resulting in long element life.

Housing - Heating elements and motor are enclosed in a heavy gauge galvanized steel cabinet with a durable camel polyester powder coat finish.

Outlet Grille - Individually adjustable louvers are provided to direct airflow. A protective outlet fan guard is provided to prevent insertion of foreign objects.

Fan Motor - Permanently lubricated and thermally protected motor.

Built-in Controls - All units include an automatic reset thermal cutout that will de-energize the heater if an overtem-

perature condition occurs. A manual reset thermal cutout, in addition to an automatic reset thermal cutout, is standard on heaters 10 KW and above. A fan delay is provided to allow the elements to heat up before fan startup and purges the heater of residual heat after shutdown. A 24-volt transformer and disconnecting contactor are provided on most heaters. Single-phase heaters rated at 5 KW or less have line voltage controls; 24-volt control and contactor are available. Power fusing is standard on all heaters rated over 48 amps.

Mounting - Universal horizontal or vertical discharge. Optional diffusers are available for vertical discharge. An Anemostat diffuser can be used to provide draft-free air movement at lower mounting heights. For higher mounting heights, radial diffuser with adjustable fins can be used to increase floor coverage or adjusted for a vertical down blast of air.

Factory Built-in Options

Code	Description
Consult Factory	Custom KW - CONSULT FACTORY
D	Power disconnect switch
F	Fusing under 48 Amps, not available on heaters size 1 and size 2 or size 3 at 600V
M	Manual Reset Cutout (In addition to automatic cutout) on heaters up to 10KW
P (1)	"Heater On" Pilot Light
R1	Built-in 24V transformer and contactor for 2.5 to 5 KW, single phase heaters.
R2 (1) (2)	120V Transformer to replace 24V Transformer
S1	Summer Fan Switch
S2 (1)	Summer Fan Switch - Remote Pilot Duty
T	Built-in Thermostat - 1 - Stage
	Built-in Thermostat - 2 - Stage (Option 'X' required)
V1*	Anemostat (Cone) Diffuser
V2	Radial Diffuser
X (2)	2-Stage Control

* consult factory for lead times

(1) When specifying Option 'P', 'R2', or 'S2' for single-phase heaters rated up to 5KW; Option 'R1' must also be specified.

(2) Option 'R2' and 'X' cannot be combined on heaters rates up to 5KW.

Field-Installed Options (shipped loose for field installation into heater)

Catalog Number	Description
BH -1024155	Anemostat (Cone) Diffuser size 1
BH -1024156	Anemostat (Cone) Diffuser size 2 and 3
BH -1024157	Anemostat (Cone) Diffuser size 4
BH -1024152	Radial Diffuser size 1
BH -1024153	Radial Diffuser size 2 and 3
BH -1024154	Radial Diffuser size 4
BH -1023941	Horizontal Dust Shield size 1 and 2
BH -1024059	Horizontal Dust Shield size 3
BH -1024060	Horizontal Dust Shield size 4
BH -1024162	Disconnect Switch, 600V, Three-Pole, 32 Amp
BH -1024163	Disconnect Switch, 600V, Three-Pole, 64 Amp
BH -1024164	Disconnect Switch, 600V, Three-Pole, 80 Amp
BH -1024166	Built-in Thermostat - 1 - Stage
BH -1024167	Built-in Thermostat - 2 - Stage (Option 'X' required)
BH -1024168 (1)	Heater On Pilot Light (24V)
BH -1024169 (1)(2)	Heater On Pilot Light (120V)
BH -1024170	Summer Fan Switch - Built-in up to 277V
BH -1024171	Summer Fan Switch- Built-in, over 277V, 24V Control
BH -1024172 (1)	Summer Fan Switch - Remote, 24V Control
BH -1031847	Summer Fan Switch - Built-in, over 277V, 120V Control
BH -1031848	Summer Fan Switch - Remote, 120V Control

(1) When specifying Option 'P', 'R2', or 'S2' for single-phase heaters rated up to 5KW; Option 'R1' must also be specified.

(2) Option 'R2' and 'X' cannot be combined on heaters rates up to 5KW.

Vertical Mounting Air Pattern Table

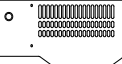
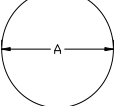
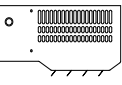
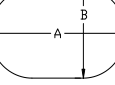
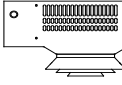
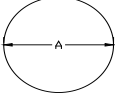
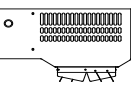
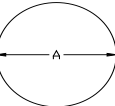
Description	Used on	Max Mtg. Height ft. (m)	A ft (m)	B ft (m)
WITHOUT DIFFUSER For a straight downward air pattern, directional louvers can be removed in order to maximize airflow.  	Size 1 up to 5 kW Size 2 over 5 up to 10 kW Size 3 over 10 up to 20 kW Size 4 over 20 up to 50 kW	10 (3.0) 15 (4.6) 20 (6.1) 25 (7.6)	17 (5.2) 28 (8.5) 38 (11.6) 68 (20.7)	— — — —
DIRECTIONAL LOUVERS (standard) Provides a directional (straight line) airflow which results in a rectangular air pattern. Louvers can be adjusted through a 35 degree range of motion  	Size 1 up to 5 kW Size 2 over 5 up to 10 kW Size 3 over 10 up to 20 kW Size 4 over 20 up to 50 kW	10 (3.0) 15 (4.6) 20 (6.1) 25 (7.6)	22 (6.7) 40 (12.2) 53 (16.2) 85 (25.9)	12 (3.7) 20 (6.1) 27 (8.2) 45 (13.7)
ANEMOSTAT DIFFUSER Ideal for low mounting heights. Fabricated using 3 diverging hollow cones which disperse heat to the floor area at a minimum velocity for comfort.  	Size 1 up to 5 kW Size 2 over 5 up to 10 kW Size 3 over 10 up to 20 kW Size 4 over 20 up to 50 kW	9 (2.7) 13 (4.0) 17 (5.2) 21 (6.4)	17 (5.2) 29 (8.8) 40 (12.2) 68 (20.7)	— — — —
RADIAL DIFFUSER Ideal for high ceiling mounting. Louvers can be adjusted to direct airflow straight down when fully open to 45 degrees in a radial pattern which increases floor coverage by approximately 20%.  	OPEN Size 1 up to 5 kW Size 2 over 5 up to 10 kW Size 3 over 10 up to 20 kW Size 4 over 20 up to 50 kW	10 (3.0) 15 (4.6) 20 (6.1) 25 (7.6)	20 (6.1) 30 (9.1) 38 (11.6) 65 (19.8)	— — — —
	45° Size 1 up to 5 kW Size 2 over 5 up to 10 kW Size 3 over 10 up to 20 kW Size 4 over 20 up to 50 kW	9 (2.7) 11 (3.4) 15 (4.5) 18 (5.5)	24 (7.3) 36 (11.0) 46 (14.0) 78 (23.8)	— — — —

240 Series

UNIT HEATER

Heater Listing

KW	Volts	Ph	Total Amps*	Approx. Air Temperature Rise °F (°C)	2-Stage Control	Std. Control Voltage	Unit Size	Catalog Number (2)
2.5	208	1	12.30	23 (13)	1B	208	1	BH-240-U1025C
	240	1	10.7		1B	240	1	BH-240-U1025J
	277	1	9.40		1B	277	1	BH-240-U1025N
3.3	208	1	16.17	31 (18)	1B	208	1	BH-240-U1033C
	240	1	14.05		1B	240	1	BH-240-U1033J
	277	1	12.21		1B	277	1	BH-240-U1033N
3.7	480	3	4.66	34 (19)	1A	24	1	BH-240-U1037U
3.8	208	3	10.85	35 (20)	1A	24	1	BH-240-U1038D
	240	3	9.44		1A	24	1	BH-240-U1038K
5	208	1	24.34	46 (26)	1B	208	1	BH-240-U1050C
	240	1	21.13		1B	240	1	BH-240-U1050J
	277	1	18.35		1B	277	1	BH-240-U1050N
	208	3	14.18		1A	24	1	BH-240-U1050D
	240	3	12.33		1A	24	1	BH-240-U1050K
	480	3	6.22		1A	24	1	BH-240-U1050U
6.7	208	1	32.91	33 (19)	1B	24	2	BH-240-U2067C
	240	1	28.62		1B	24	2	BH-240-U2067J
	277	1	24.79		1B	24	2	BH-240-U2067N
7.5	208	1	36.80	37 (21)	1B	24	2	BH-240-U2075C
	240	1	32.00		1B	24	2	BH-240-U2075J
	208	3	21.52		1A	24	2	BH-240-U2075D
	240	3	18.74		1A	24	2	BH-240-U2075K
	480	3	9.39		1A	24	2	BH-240-U2075U
9.9	208	1	48.30	49 (28)	1B	24	2	BH-240-U2099C
10	240	1	42.37	50 (28)	1B	24	2	BH-240-U2100J
	277	1	36.70		1B	24	2	BH-240-U2100N
	208	3	28.46		1A	24	2	BH-240-U2100D
	240	3	24.76		1A	24	2	BH-240-U2100K
	480	3	12.40		1A	24	2	BH-240-U2100U
13.2	277	1	48.35	39 (22)	1B	24	3	BH-240-U3132N
13.3	208	1	64.79	39 (22)	Standard	24	3	BH-240-U3133C-X (1)
	240	1	56.27		Standard	24	3	BH-240-U3133J-X
15	208	3	42.48	44 (25)	1B	24	3	BH-240-U3150D
	240	3	36.93		1B	24	3	BH-240-U3150K
	480	3	18.44		1B	24	3	BH-240-U3150U
	600	3	14.43		1B	120	3	BH-240-U3150Z (3)
19.9	208	1	96.52	59 (33)	Standard	24	3	BH-240-U3199C-X (1)
	240	3	48.72		1B	24	3	BH-240-U3199K
20	240	1	84.18	59 (33)	Standard	24	3	BH-240-U3200J-X (1)
	277	1	72.90		Standard	24	3	BH-240-U3200N-X (1)
	208	3	56.36		Standard	24	3	BH-240-U3200D-X
	480	3	24.46		1B	24	3	BH-240-U3200U
	600	3	19.25		1B	120	3	BH-240-U3200Z (3)
25	208	3	70.90	27 (15)	Standard	24	4	BH-240-U4250D-X
	240	3	61.64		Standard	24	4	BH-240-U4250K-X
	480	3	30.77		1B	24	4	BH-240-U4250U
	600	3	24.06		1B	24	4	BH-240-U4250Z
33.3	208	3	93.93	36 (20)	Standard	24	4	BH-240-U4333D-X
	240	3	81.61		Standard	24	4	BH-240-U4333K-X
	480	3	40.75		1B	24	4	BH-240-U4333U
	600	3	32.04		1B	24	4	BH-240-U4333Z
37.5	208	3	105.59	40 (23)	Standard	24	4	BH-240-U4375D-X
	240	3	91.71		Standard	24	4	BH-240-U4375K-X
	480	3	45.80		1A	24	4	BH-240-U4375U
	600	3	36.08		1A	24	4	BH-240-U4375Z
49.8	208	3	139.73	54 (30)	Standard	24	4	BH-240-U4498D-X
50	240	3	121.8	54 (30)	Standard	24	4	BH-240-U4500K-X
	480	3	60.84		Standard	24	4	BH-240-U4500U-X
	600	3	48.11		Standard	24	4	BH-240-U4500Z-X

*Total Amps = Heating element amps and motor amps.

(1) Disconnect switch unavailable.

(2) All Standard heaters are supplied with transformer and contactor except up to 5 KW single-phase units.

Optional low voltage transformer and contactor are available for these heaters, see Factory Built-in Option 'R1'.

(3) Fusing, Option "F" not available. Option 'R2' (120V Control) is standard, 24V available

2-stage heaters can be field wired as single stage.

1A = Optional 2-stage control, unbalanced (option X)

1B = Optional 2-stage control, balanced (option X).

240 Series UNIT HEATER

Heater Dimensions

Unit Size	KW	W In. (mm)	H In. (mm)	Depth In. (mm)	A In. (mm)	B In. (mm)	C In. (mm)	D In. (mm)	E In. (mm)	F In. (mm)	G In. (mm)	H In. (mm)	I In. (mm)	J In. (mm)
Size 1	up to 5	12.875 (327)	17.750 (450)	7.625 (194)	8 (203)	10.188 (284)	18 (457)	10 (254)	8 (203)	16 (406)	5 (127)	6.44 (164)	6.44 (164)	5 (127)
Size 2	5.1 to 10	16.875 (429)	24.250 (616)	7.625 (194)	6 (152)	10.188 (284)	18 (457)	10 (254)	8 (203)	16 (406)	5 (127)	6.44 (164)	6.44 (164)	5 (127)
Size 3	10.1 to 20	16.875 (429)	24.250 (616)	11.375 (289)	6 (152)	8.313 (237)	18 (457)	12 (305)	12 (305)	32 (813)	5 (127)	10.13 (257)	5 (127)	10.13 (257)
Size 4	20.1 to 50	26.937 (684)	35.500 (902)	15.625 (397)	6.281 (236)	11.937 (380)	13 (330)	12 (305)	16 (406)	32 (813)	7 (178)	12.92 (328)	7 (178)	12.92 (328)

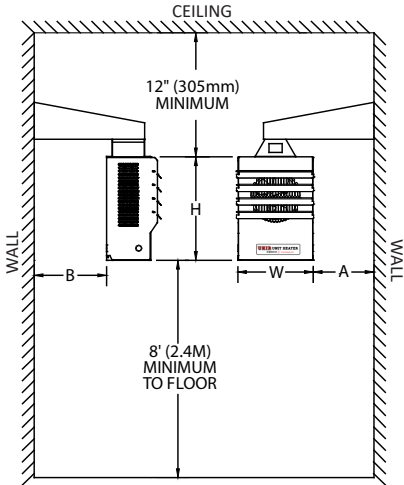

FIG. 1
HORIZONTAL WALL MOUNTING WITH MOUNTING ARM

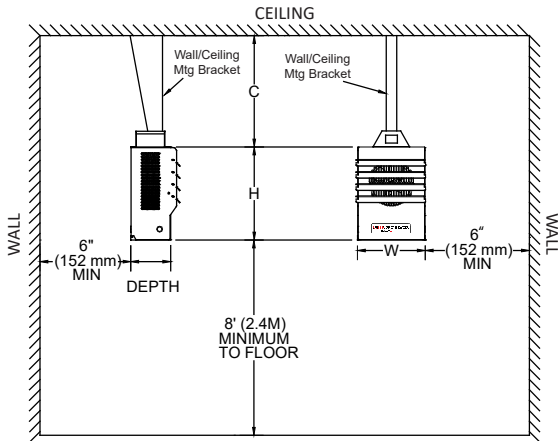

FIG. 2
HORIZONTAL CEILING MOUNT WITH MTG ARM

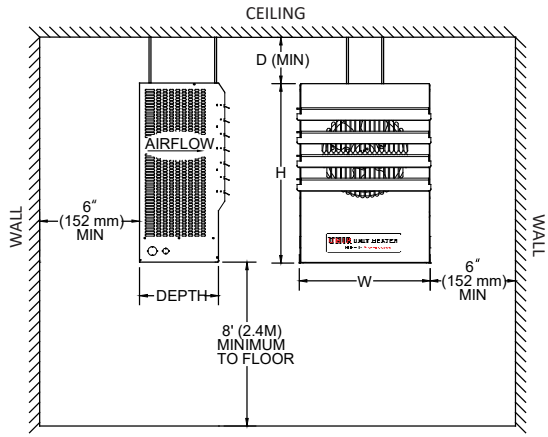

FIG. 3
HORIZONTAL CEILING MOUNT WITH THREADED ROD

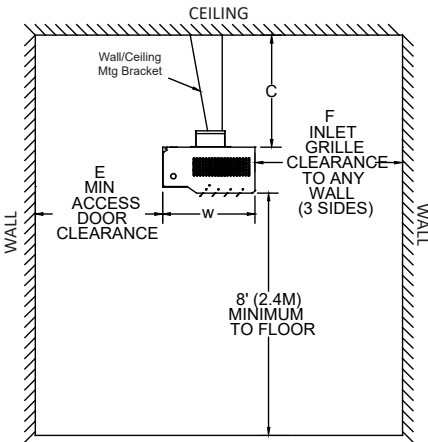

FIG. 4
VERTICAL CEILING MOUNT WITH MTG ARM

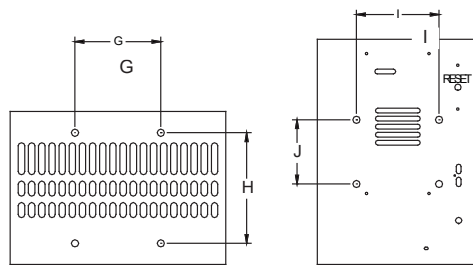

FIG. 5
THREADED ROD (3/8 - 16) ATTACHMENT POINT DIMENSIONS

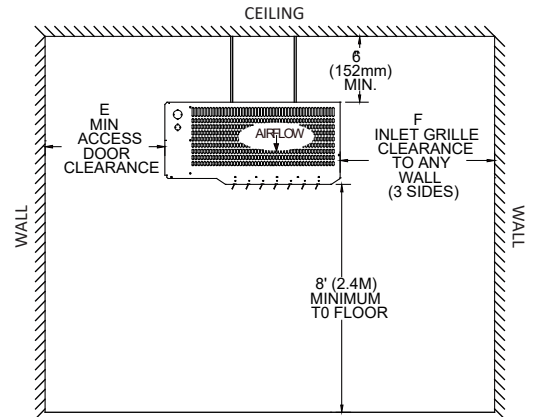

FIG. 6
VERTICAL CEILING MOUNT WITH THREADED ROD

240 Series

UNIT HEATER

Mounting Brackets

Catalog Number	Description
BH -1024149	Universal wall & ceiling mounting bracket up to 10 KW (size 1 and 2)
BH -1024150	Universal wall & ceiling mounting bracket over 10 KW up to 20 KW (size 3)
BH -1024151	Universal wall & ceiling mounting bracket over 20 KW (size 4)

Airflows, Weights and Air Throw

Unit Size	CFM	Installed Weight lb (kg)	Max. Air Throw ft. (m)
1	350	25 (11.3)	15 (4.6)
2	650	40 (18.1)	18 (5.5)
3	1100	55 (25)	41 (12.5)
4	3000	155 (70.3)	62 (18.9)

Remote Thermostat Selection Chart

KW	Catalog Number	Volts	Ph	1-Stage Line Voltage	1-Stage Low Voltage (b)	2-Stage Low Voltage (b)
2.5	BH-240-U1025C	208	1	1007014	1006998 (a)	1007030 (a)
	BH-240-U1025J	240	1	1007014	1006998 (a)	1007030 (a)
	BH-240-U1025U	277	1	1007014	1006998 (a)	1007030 (a)
3.3	BH-240-U1033C	208	1	1007014	1006998 (a)	1007030 (a)
	BH-240-U1033J	240	1	1007014	1006998 (a)	1007030 (a)
	BH-240-U1033N	277	1	1007014	1006998 (a)	1007030 (a)
3.7	BH-240-U1037U	480	3	NA	1006998	1007030
3.8	BH-240-U1038D	208	3	NA	1006998	1007030
	BH-240-U1038K	240	3	NA	1006998	1007030
5	BH-240-U1050C	208	1	NA	1006998 (a)	1007030 (a)
	BH-240-U1050J	240	1	1007014	1006998 (a)	1007030 (a)
	BH-240-U1050N	277	1	1007014	1006998 (a)	1007030 (a)
All Other 240 Ser Heaters				NA	1006998	1007030

(a) Add option 'R1' for 24V control on these units.

(b) Option 'R2' is unavailable with any Brasch supplied remote low voltage thermostats.

*Add option code to catalog number, mounting brackets or field installed options where applicable



1007030

1007014

1006998

Color Selection Chart

Standard Colors 900 Series



Beige = N

White = W

Special Colors 900 Series



Black = B

Aluminum = A

Bronze = S

Charcoal Gray = G

Refer to catalog listings for standard and special color availability. Use color codes in parentheses when specifying and ordering. Custom colors are also available on 900 Series. Special and Optional Colors subject to setup charges. Colors represented are approximate.

925 Series

GENERAL INDUSTRIAL/COMMERCIAL UNIT HEATER



Technical Specifications:

- Temp Range: 45°–90°F
- CFM: 270–1800

Applications:

- Factories
- Warehouses
- Garages
- Service Stations
- Stockrooms
- Workshops
- Stores
- Stairwells
- Maintenance Rooms

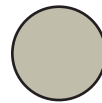

Beige

Standard Construction Features

- Heater comes equipped with ceiling-mount bracket for horizontal or vertical flow mounting or any position in between
- Built-in single-pole thermostat
- Copper-brazed steel fins with steel sheathed tubular elements for uniform heating and longevity
- Adjustable louvers control air throw direction
- Automatic fan delay eliminates cold drafts on start-up and discharges residual heat from the heater body during shut down
- High limit cut-off with visual alarm automatically shuts off current in event of overheating and reactivates unit when temperature returns to normal
- Disconnect switch (DS30) option available for heaters 24 amps or lower.

925 Series

GENERAL INDUSTRIAL/COMMERCIAL UNIT HEATER

Models & Specifications:

ITEM INFORMATION	ELECTRICAL DATA				
CATALOG NO.	VOLTS	WATTS	BTU/HR.	HEATER AMPS	SHIP WT.
925BU-UH5004-N	208	1874	6396	9	24 lbs
		2500	8553	12	
		3123	10659	15	
		3750	12799	18	
	240	2500	8533	10.4	
		3332	11365	13.9	
		4165	14215	17.4	
925BU-UH7504-N	208	2812	9598	13.5	27 lbs
		3750	12799	18	
		4685	15990	22.5	
		5625	19198	27.1	
		7500	25598	31.3	
	240	3750	12799	15.6	
		5000	17065	20.8	
		6250	21331	26	
		7500	25598	31.3	
		7500	25598	31.3	
925BU-UH5008-N	208	2500	8533	12	26 lbs
		3332	11365	16	
		4165	14215	20	
		5000	17065	24	

NOTE: Disconnect switch (UIS-DS30-X) option available for heaters 24 amps or lower. Optional UIB-CWB1-N combination wall/ceiling bracket available.

Dimensions and Clearances:

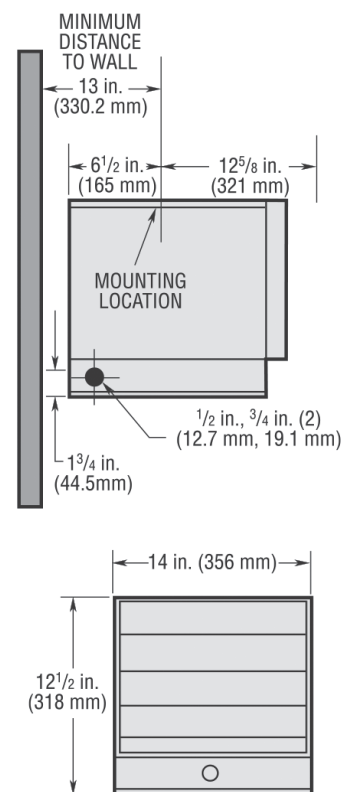

Controls and Accessories:

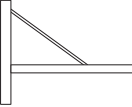
	CATALOG NO.	DESCRIPTION
	UIS-DS30-X	3-pole power disconnect switch for field installation on all heaters. Complies with "positive off" requirements.
	UIB-CWB1-N	Wall mounting brackets for all units. (Ceiling mounting bracket is included with all heaters.)

961 Series

CONFINED SPACE UNIT HEATER



Brasch's confined space plenum rated unit heater is the perfect heating solution for parking garages and other confined spaces.

Applications

- Parking Garages
- Crawl Spaces
- Inside Plenums
- Above Drop Ceilings

- Easily fits between joist for typical installation.
- Zero Clearance for wall and ceiling mounting as well as floor mounting with appropriate inlet and outlet clearances.
- Bracket standard or can be mounted by 3/8" threaded rod (field supplied).
- Automatic reset thermal limit for safety.
- 1-phase model wattage field changeable from 1874 to 5000 watts.
- 24V control circuit on three phase models with hydraulic thermostat.
- Made in the USA.

Standard Construction Features

Heating Elements – Heavy-duty block fin element design. The heating element is located directly in front of the fan discharge air for uniform heating. The multiple tap electric design is factory wired for 5 kW and allows for field conversion to eight wattages at 208/240 volts single phase or at 208, 240 and 480 volts three phase.

Cabinet – The cabinet is made of heavy gauge steel casing and finished with two tone, brown and beige, durable powder coating. The bottom panel allows for access to the controls without dismounting the heater.

Control Box – Gasket control box cover to prevent dust and dirt from entering the control box. All heater wiring and controls are located at the bottom of the heater and equipped with a removable cover held in place by four screws to permit full access for installation and servicing without dismounting the heater. 24-Volt control circuit is standard on three phase heaters. Inlet and outlet protective screens are provided to prevent contact with the fan and elements.

Disconnect Switch – Optional field installed disconnect switch for full electrical disconnection at site of the heater as required by NEC.

Safety Thermal Cutouts – Automatic reset thermal safety cutout is built-in to shut off heater in the event of overheating due to any cause.

Fan Delay Control – Fan control to delay fan startup of the fan motor until the heating elements have warmed up and continue fan operation after heating elements have been de-energized to dissipate residual heat.

Temperature Control – The heater includes a built-in adjustable hydraulic thermostat.

Zero Clearance – The heater is rated for zero clearance to any surface mounted next to the sides, top, and bottom of the metal cabinet.

Fan Motor – Fan motor is totally enclosed permanently lubricated with thermal overload protection. Fan motor and controls operate directly from the line voltage.

961 Series

CONFINED SPACE UNIT HEATER

Field-Installed Options

Catalog Number	Description	Availability Code (2)
1031082	Disconnect switch, 30 Amp @ 600 Volts	AS

Heater Listing

Catalog Number	Watts (3)	BTUs	Volts (1)	Phase	Total Amps	Temp Rise °F (°C)	Temp Range °F (°C)	Air Throw (Ft.)	CFM	Wt. (Lbs)	Availability Code (2)
BH-P-961U5000V-T	5000	17065	240	1	21	57	40-120 (5-49)	16	275	32	AS
	4165	14215			17	48					
	3332	11365			14	38					
	2500	8533			10	29					
	3750	12798	208	1	18	43	40-120 (5-49)	16	275	32	
	3123	10659			15	36					
	2500	8553			12	29					
	1874	6396			9	21					
BH-P-961U5000K-T	3750	12799	208	3	10.4	43	40-110 (5-43)	16	275	32	
	5000	17065	240		12	57			275		
BH-P-961U5000U-T	5000	17065	480	3	6	57	40-110 (5-43)	16	275	32	

- (1) 60 Hz only
- (2) AS = Assemble Stock, AS listed heaters ordered with custom (C) features are subject to longer lead times.
- (3) 240/208 single phase unit is factory wired for 5kW. The heater may be field changed to listed wattages, see IOM for instructions.
- (4) Mounting bracket and built-in thermostat included.

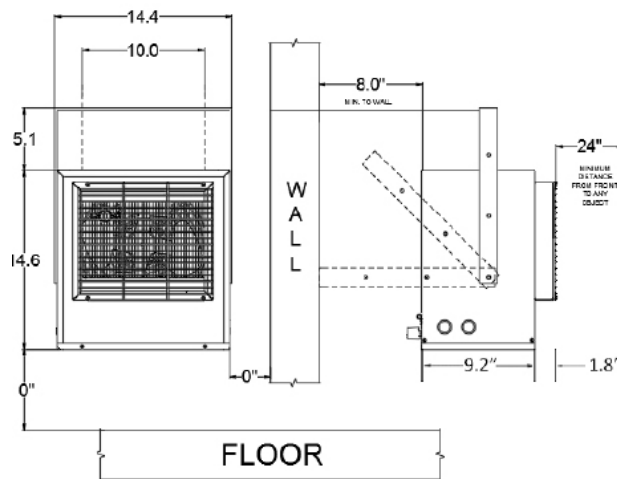

962 Series

PLENUM RATED UNITS FOR ENCLOSED SPACES



Applications

- Concealed Areas
- Concession Stands
- Plenum Areas
- Large Entry Ways

Brasch's 962 Series plenum heater is versatile by design and is easily serviceable, if ever needed.

- 20 gauge galvanized cabinet.
- Variable speed motor, factory set at maximum. Motor speed can be field adjusted to increase heat rise.
- Acoustically insulated with 1" fiberglass.
- Access panels on both sides of cabinet.
- 24 Volt controls./ Disconnect Switch.
- Airflow switch.
- Terminal blocks.
- Single point connection
- Dust tight control enclosure.
- Filter rack on inlet with throw-away filter.
- Inlet and outlet screens and duct connection.
- Automatic primary limit control and secondary fuse link.
- Optional wall thermostat, unit thermostat or SSR control which proportionally regulates heat output.
- Made in the USA.

Standard Construction Features

Heating Elements - The heating elements are 80% nickel and 20% chromium resistance wire. The heating elements are located directly in front of the blower discharge for uniform heating.

Cabinet - The cabinet is constructed of 20 gauge galvanized steel with 1" of acoustic fiberglass insulation. Inlet and outlet are fitted with protective screens and suitable for duct connection. Access panels to fan(s) are on both sides of the cabinet. Heater control enclosure is dust tight.

Operation - The heater and fan(s) operation is controlled by either built-in or remote thermostat. Fan motor speed is field adjusted to provide desired temperature rise.

Safety Thermal Cutouts - An automatic resetting thermal cutout for primary and fuse link cutout(s) for secondary over-temperature protection is built into the unit to provide zero clearance to combustible materials.

Motor and Blower Assembly - The PSC motor(s) and blower(s) are direct drive and resiliently mounted on a rigid heavy gauge frame for quiet operation and long life. The motor(s) is rated for continuous operation and is provided with automatic reset overload. The blower(s) is forward curved, double inlet, centrifugal type with discharge directly on the full length of the elements to provide uniform discharge air temperatures.

Air Filters - Inlet filter(s) is provided to assure clean air circulation. The throw away filter(s) is easily removed for changing from outside of the unit.

Disconnect Switch - The unit includes a door interlocking disconnect rated at a minimum of 125% of the total electrical load and has a single point electrical connection for the unit.

Built-In Controls - Clearly labeled power and control terminal blocks are provided for all field electrical connections. Pressure differential airflow switch(s) is provided to interlock airflow with the operation of the unit. Power fusing is provided for units over 48 amps as required by NEC. Magnetic disconnecting contactor(s) for stage and safety control circuit interlock, fan relay and adjustable motor speed controller are provided. Control terminal block allows for remote disabling of the fan, remote switch to be provided by the installer.

Temperature Control - The unit is designed to be controlled by a remote thermostat. Thermostat field connections are made at a clearly marked control terminal block located inside the heater enclosure.

Fan Speed - The variable fan motor speed control is field adjustable to increase temperature rise, factory set at maximum. Controller is located inside the control enclosure for ease of adjustment.

962 Series

PLENUM RATED UNITS FOR ENCLOSED SPACES

Factory Built-in Options

Code	Description	Availability Code (2)
T	1-Stage built-in adjustable thermostat	AS
	2-Stage built-in adjustable thermostat	
U4L6	Optional left and connection in place of standard right hand.	

Accessory Remote Room Thermostat

Catalog Number	Description	Availability Code (2)
1006998	Single-Stage Low Voltage Remote Thermostat - White - Bimetal	AS
1007030	Two-Stage Low Voltage Remote Thermostat - White - Bimetal	
1032432	Low Voltage Electronic Duct Discharge Sensor - SSR Controlled heater	

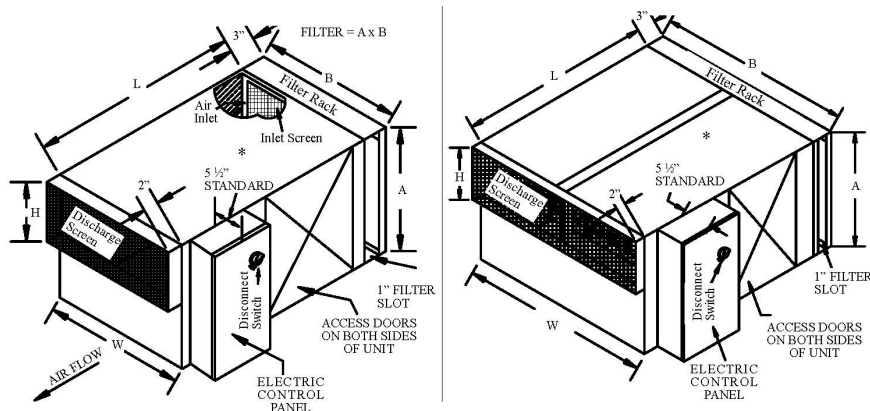

Control panel access right hand (U6L4) is standard as shown. For panel on opposite side access specify left hand (U4L6).

962 Series	Dimensions					Weight
	A (In.)	B (In.)	L (In.)	Discharge		
				W	H	
3 KW	12	14	32	14	8	98
5 KW	14	18	36	18	8	118
10 & 15 KW	18	18	36	18	10	141
20 KW	18	22	36	22	10	163
23 & 25 KW	18	26	36	26	10	201

962 Series	Dimensions					Weight
	A (In.)	B (In.)	C (In.)	Discharge		
				W	H	
25-30-25 KW	18	44	36	44	10	278
40-45-50 KW	18	52	36	52	10	319

* Note: Control box depth depends on actual components. Consult factory for exact dimensions.

962 Series

PLENUM RATED UNITS FOR ENCLOSED SPACES

Heater Listing - Stage Controlled Heaters

Catalog Number	KW	CFM Range	Volts/ Phase (1)	Total Amps for Motor & Heater	Stage	Motor Voltage	Full Load Amps for Motor	Motor HP	Wt. (Lbs.)	Availability Code (2)
BH-P-962U1N03C-DU6L4	3	70-270	208/1	15.4	1	277	1	1/15	98	AS
BH-P-962U1N03J-DU6L4			240/1	13.5						
BH-P-962U1N03N-DU6L4			277/1	11.83						
BH-P-962U1N03D-DU6L4			208/3	9.32						
BH-P-962U1N03K-DU6L4			240/3	8.21						
BH-P-962U1N05C-DU6L4	5	200-650	208/1	25.13	1	277	1.1	1/6	118	
BH-P-962U1N05J-DU6L4			240/1	21.93						
BH-P-962U1N05N-DU6L4			277/1	19.15						
BH-P-962U1N05D-DU6L4			208/3	14.97						
BH-P-962U1N05K-DU6L4			240/3	13.12						
BH-P-962U1T05U-DU6L4			480/3	7.11		480				
BH-P-962U1N10D-DU6L4	10	500-1200	208/3	29.45	1	277	1.7	1/4	141	
BH-P-962U1N10K-DU6L4			240/3	25.75						
BH-P-962U1N10U-DU6L4			480/3	13.72						
BH-P-962U2N10D-DU6L4			208/3	29.45	2					
BH-P-962U2N10K-DU6L4			240/3	25.75						
BH-P-962U2T10U-DU6L4			480/3	13.75						
BH-P-962U1N15D-DU6L4	15	500-1200	208/3	43.33	1	277	1.7	1/4	141	
BH-P-962U1T15U-DU6L4			240/3	37.78						
BH-P-962U1T15U-DU6L4			480/3	19.74						
BH-P-962U2N15D-DU6L4			208/3	43.3	2					
BH-P-962U2N15K-DU6L4			240/3	37.78						
BH-P-962U2T15U-DU6L4			480/3	19.74						
BH-P-962U2N20D-DU6L4	20	750-1600	208/3	58.01	2	277	2.5	1/2	163	
BH-P-962U2N20K-DU6L4			240/3	50.61						
BH-P-962U2T20U-DU6L4			480/3	26.55						480
BH-P-962U2N23D-DU6L4	23	1300-2000	208/3	68.14	2	277	4.3	3/4	210	
BH-P-962U2N23K-DU6L4			240/3	59.63						
BH-P-962U2T25U-DU6L4			480/3	34.37						480
BH-P-962U2N30K-DU6L4	30	1800-2800	240/3	78.47	2	277	6.3	2Motors @ 1/2 HP each	278	
BH-P-962U2T30U-DU6L4			480/3	42.38		480				
BH-P-962U2T35U-DU6L4			480/3	48.39		480				
BH-P-962U2T40U-DU6L4	40	2000-3600	480/3	56.71	2	480	8.6	2Motors @ 3/4 HP each	319	
BH-P-962U2T45U-DU6L4	45			62.72						
BH-P-962U2T50U-DU6L4	50			68.74						

962 Series

PLENUM RATED UNITS FOR ENCLOSED SPACES

Heater Listing - SSR Controlled Heaters

Catalog Number	KW	CFM Range	Volts/Phase (1)	Total Amps for Motor & Heater	Stage	Motor Voltage	Full Load Amps for Motor	Motor HP	Wt. (Lbs.)	Availability Code (2)	
BH-P-962U1N03C-DEU6L4	3	70-270	208/1	15.4	SSR	277	1	1/15	98	C	
BH-P-962U1N03J-DEU6L4			240/1	13.5							
BH-P-962U1N03N-DEU6L4			277/1	11.83							
BH-P-962U1N03D-DEU6L4			208/3	9.32							
BH-P-962U1N03K-DEU6L4			240/3	8.21							
BH-P-962U1N05C-DEU6L4	5	200-650	208/1	25.13		277	1.1	1/6	118		
BH-P-962U1N05J-DEU6L4			240/1	21.93							
BH-P-962U1N05N-DEU6L4			277/1	19.5							
BH-P-962U1N05D-DEU6L4			208/3	14.97							
BH-P-962U1N05K-DEU6L4			240/3	13.12							
BH-P-962U1T05U-DEU6L4			480/3	7.11		480					
BH-P-962U1N10D-DEU6L4	10	500-1200	208/3	29.45		277	1.7	1/4	141		
BH-P-962U1N10K-DEU6L4			240/3	25.75							
BH-P-962U1N10U-DEU6L4			480/3	13.72							
BH-P-962U1N15D-DEU6L4	15	500-1200	208/3	43.33		277	1.7	1/4	141		
BH-P-962U1N15K-DEU6L4			240/3	37.78							
BH-P-962U1T15U-DEU6L4			480/3	19.74							
BH-P-962U2T20U-DEU6L4	20	750-1600	480/3	26.55	480	2.5	1/2	163			
BH-P-962U2T25U-DEU6L4	25	1300-2000	480/3	34.37					4.3	3/4	201
BH-P-962U2T30U-DEU6L4	30	1800-2800	480/3	42.38							
BH-P-962U2T35U-DEU6L4	35		480/3	48.39					6.3	2 Motors @ 1/2 HP each	278

(1) 60 Hz only

(2) AS = Assemble Stock, AS listed heaters ordered with custom (C) features are subject to longer lead times.

(3) Default/standard hand-of-connection is right hand (U6L4) optional left hand (U4L6) is available, see optional features.

(4) Built-in door interlocking disconnect switch is included.

(5) Includes Viconics VT7225 Remote Thermostat.

963 Series

LOW PROFILE PLENUM HEATER



Applications

- Low Clearance Ceilings
- Low Clearance Floors
- Concealed Areas
- Concession Stands
- Plenum Areas
- Large Entry Ways

Brasch's low profile plenum heater is designed to fit jobs where the clear space between the ceiling and the floor above is as small as 11-3/4 inches.

- 20 gauge galvanized cabinet.
- Variable speed motor, factory set at maximum. Motor speed can be field adjusted to increase heat rise.
- Acoustically insulated with 1" fiberglass.
- Access panels on bottom of unit.
- 24 Volt controls / Disconnect Switch.
- Airflow switch.
- Terminal blocks.
- Single point connection
- Dust tight control enclosure.
- Filter rack on inlet with throw-away filter.
- Inlet and outlet screens and duct connection.
- Automatic primary limit control and secondary fuse link.
- Optional wall thermostat, unit thermostat or SSR control which proportionally regulates heat output.
- Made in the USA.

Standard Construction Features

Heating Elements - The heating elements are 80% nickel and 20% chromium resistance wire. The heating elements are located directly in front of the blower discharge for uniform heating.

Cabinet - The cabinet is constructed of 20 gauge galvanized steel with 1" of acoustic fiberglass insulation. Inlet and outlet are fitted with protective screens and suitable for duct connection. Access panels to fan(s) are on both sides of the cabinet. Heater control enclosure is dust tight.

Operation - The heater and fan(s) operation is controlled by either built-in or remote thermostat. Fan motor speed is field adjusted to provide desired temperature rise.

Safety Thermal Cutouts - An automatic resetting thermal cutout for primary and fuse link cutout(s) for secondary over-temperature protection is built into the unit to provide zero clearance to combustible materials.

Motor and Blower Assembly - The PSC motor(s) and blower(s) is direct drive and resiliently mounted on a rigid heavy gauge frame for quiet operation and long life. The motor(s) is rated

for continues operation and is provided with automatic reset overload. The blower(s) is forward curved, double inlet, centrifugal type with discharge directly on the full length of the elements to provide uniform discharge air temperatures.

Air Filters- Inlet filter(s) is provided to assure clean air circulation. The throw away filter(s) is easily removed for changing from outside of the unit.

Disconnect Switch -The unit includes a door interlocking disconnect rated at a minimum of 125% of the total electrical load and has a single point electrical connection for the unit.

Built-In Controls - **Built-In Controls** - Clearly labeled power and control terminal blocks are provide for all field electrical connections. Pressure differential airflow switch(s) is provide to interlock airflow with the operation of the unit. Power fusing is provided for units

963 Series

LOW PROFILE PLENUM HEATER

Standard Construction Features (continued)

minimal blocks are provide for all field electrical connections. Pressure differential airflow switch(s) is provide to interlock airflow with the operation of the unit. Power fusing is provided for units over 48 amps as required by NEC. Magnetic disconnecting contactor(s) for stage and safety control circuit interlock, fan relay and adjustable motor speed controller is provided. Control terminal block allows for remote disabling of the fan, remote switch to be provided by the installer.

Temperature Control - The unit is designed to be controlled by a remote thermostat. Thermostat field connections are made at a clearly marked control terminal block located inside the heater enclosure.

Fan Speed - The variable fan motor speed control is field adjustable to increase temperature rise, factory set at maximum. Controller is located inside the control enclosure for ease of adjustment.

Heater Listing - Stage Controlled Heaters

Catalog Number	KW	CFM Range	Volts/Phase (1)	Total Amps for Motor & Heater	Stage	Motor Voltage	Full Load Amps for Motor	Motor HP	Wt. (Lbs.)	Availability Code (2)
BH-P-963U1N05C-DU6L4	5	170-950	208/1	26	1	277	2	1/4	163	C
BH-P-963U1N05J-DU6L4			240/1	22						
BH-P-963U1N05N-DU6L4			277/1	20						
BH-P-963U1N05D-DU6L4			208/3	15						
BH-P-963U1N05K-DU6L4			240/3	14						
BH-P-963U1T05U-DU6L4			480/3	8						
BH-P-963U1N10D-DU6L4	10		208/3	30	2	277	2			
BH-P-963U1N10K-DU6L4			240/3	26						
BH-P-963U1T10U-DU6L4			480/3	14						
BH-P-963U2N10D-DU6L4			208/3	30						
BH-P-963U2N10K-DU6L4			240/3	26						
BH-P-963U2T10U-DU6L4			480/3	14						
BH-P-963U1N12K-DU6L4	12	270-1500	240/3	32	1	277	3			
BH-P-963U1T12U-DU6L4			480/3	17		480				
BH-P-963U2N12D-DU6L4			208/3	37	2	277	2			
BH-P-963U2N12K-DU6L4			240/3	32		480	3			
BH-P-963U2T12U-DU6L4			480/3	17		480				
BH-P-963U2T12U-DU6L4	15		240/3	39	1	277	3			
BH-P-963U1T15U-DU6L4			480/3	21		480				
BH-P-963U2N15D-DU6L4			208/3	45	2	277	4			
BH-P-963U2N15K-DU6L4			240/3	39		480				
BH-P-963U2T15U-DU6L4	18		480/3	21	1	480	3			
BH-P-963U1T18U-DU6L4		480/3	25							
BH-P-963U2T18U-DU6L4		480/3	25	2						

(1) 60 Hz only

(2) AS = Assemble Stock, AS listed heaters ordered with custom (C) features are subject to longer lead times.

(3) Default/standard hand-of-connection is right hand (U6L4) optional left hand (U4L6) is available, see optional features.

(4) Built-in door interlocking disconnect switch is included.

963 Series

LOW PROFILE PLENUM HEATER

Heater Listing - SSR Controlled Heaters

Catalog Number	KW	CFM Range	Volts/Phase (1)	Total Amps for Motor & Heater	Stage	Motor Voltage	Full Load Amps for Motor	Motor HP	Wt. (Lbs.)	Availability Code (2)
BH-P-963U1N05C-DEU6L4	5	170-950	208/1	26	SSR	277	2	1/4	163	C
BH-P-963U1N05J-DEU6L4			240/1	22						
BH-P-963U1N05N-DEU6L4			277/1	20						
BH-P-963U1N05D-DEU6L4			208/3	15						
BH-P-963U1N05K-DEU6L4			240/3	14						
BH-P-963U1T05U-DEU6L4			480/3	8						
BH-P-963U1N10D-DEU6L4	10	270-1500	208/3	30		277				
BH-P-963U1N10K-DEU6L4			240/3	26		480				
BH-P-963U1T10U-DEU6L4			480/3	14		480				
BH-P-963U1N12K-DEU6L4	12	270-1500	240/3	32		277	3	2 Motors @ 1/4 HP Each	219	
BH-P-963U1T12U-DEU6L4			480/3	17		480				
BH-P-963U1N15K-DEU6L4	15	270-1500	240/3	39		277				
BH-P-963U1T15U-DEU6L4			480/3	21	480					
BH-P-963U1T18U-DEU6L4	18	270-1500	480/3	25	480					

(1) Includes Viconics VT7225 Remote Thermostat.

Factory Built-in Options

Code	Description	Availability Code (2)
T	1-Stage built-in adjustable thermostat	AS
	2-Stage built-in adjustable thermostat	
U4L6	Optional left and connection in place of standard right hand.	

Accessory Remote Room Thermostat

Catalog Number	Description	Availability Code (2)
1006998	Single-Stage Low Voltage Remote Thermostat - White - Bimetal	AS
1007030	Two-Stage Low Voltage Remote Thermostat - White - Bimetal	
1032432	Low Voltage Electronic Duct Discharge Sensor - SSR Controlled heater	

963 Series

LOW PROFILE PLENUM HEATER

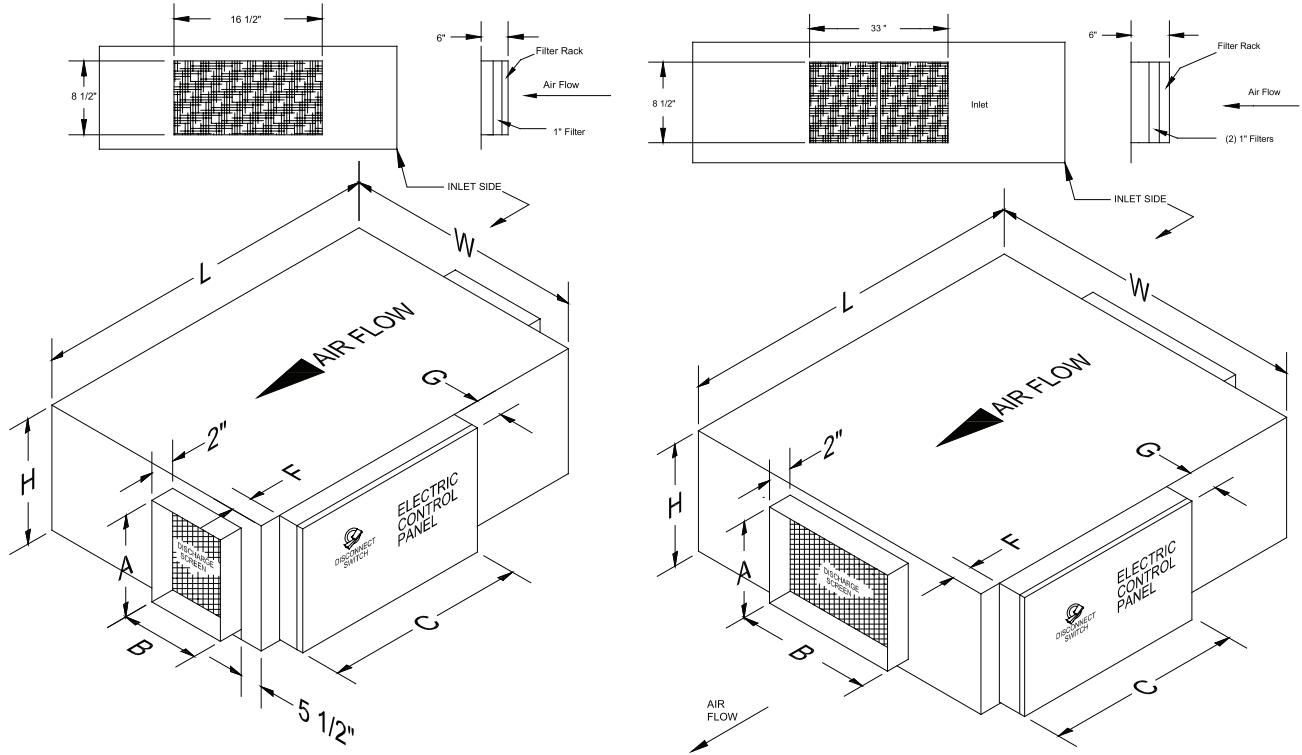

Control panel access right hand (U6L4) is standard as shown. For panel on opposite side access specify left hand (U4L6).

Dimensions								
BH-P-963	C In.	F In.	G In.	H In.	L In.	W In.	Discharge	
							A	B
5 & 10 KW	28.75	1	6	11.75	45	26	8	10

Dimensions								
BH-P-963	C In.	F In.	G In.	H In.	L In.	W In.	Discharge	
							A	B
12, 15 & 18KW	28.75	2	6	11.75	45	43	8	20

Note: Dimensions C and G will vary with accessories.

Limited Warranty

Brasch new products are warranted against defects in workmanship, material, design, labeling and packaging. No other warranty, expressed or implied, written or oral, applies. No person other than an officer or the general manager of Brasch is authorized to give any other warranty or assume any liability.

Warranty Period

18 months from the date of shipment from Indeeco's factory, or 12 months from the date the product is first placed into service, whichever period lapses first.

Conditions of Warranty

Brasch products must be installed, operated, and maintained in accordance with Brasch's instructions. Brasch is not liable for damage or unsatisfactory performance of the product resulting from accident, negligence, alteration, unauthorized repair, improper application or installation of the product, improper specifications, or corrosion. Brasch IS NOT LIABLE FOR ANY INCIDENTAL OR CONSEQUENTIAL DAMAGES. Claims against carriers for damage in transit must be filed by the purchaser with the carrier.

Remedy

Contact Brasch sales department at 1-888-731-7010 or sales@Braschmfg.com, for a Return Material Authorization Number (RMA#) and return instructions.

If after receipt of the product and the claim, Brasch finds to its reasonable satisfaction that the product is defective in workmanship, material, design, labeling or packaging, the product will be repaired or replaced, or the purchase price refunded at Brasch's option. There will be no charge to the purchaser for parts or labor. Removal and reinstallation of the product, and shipment of the product to Brasch for repair or inspection, shall be at the purchaser's risk and expense.

THE REPAIR, REPLACEMENT, OR REFUND PROVIDED FOR IN THIS LIMITED WARRANTY IS THE EXCLUSIVE REMEDY OF THE PURCHASER. THIS WARRANTY IS EXPRESSLY IN LIEU OF ANY OTHER, INCLUDING ANY WARRANTY OF MERCHANTABILITY OR FITNESS FOR A PARTICULAR PURPOSE. THERE ARE NO WARRANTIES WHICH EXTEND BEYOND THE TERMS OF THIS LIMITED WARRANTY.

Warranty Period

Brasch Product Line	Warranty Period
BBI (903)	1 year* and 10 years on heating element
BISI/BII (905/907)	1 year* and 5 years on heating element
BCI (906)	1 year* and 5 years on heating element
BASI (908)	1 year* and 5 years on heating element
BAI/BAPI (909/911)	1 year* and 5 years on heating element
LBAI/LBAPI (912/913)	1 year* and 5 years on heating element
BMI (914)	1 year* and 5 years on heating element
BHI (916)	1 year* and 5 years on heating element
RCI (918)	1 year* and 5 years on heating element
CUI (922)	1 year* and 5 years on heating element
ULIR (925)	1 year* and 5 years on heating element
WRI (930)	1 year* and 5 years on heating element
CCI (931)	1 year* and 5 years on heating element
WCI (932)	1 year* and 5 years on heating element
WAI (933)	1 year* and 5 years on heating element
WLI (934)	1 year* and 1 year on heating element
CDI (937)	1 year* and 5 years on heating element
TSI (938)	1 year* and 5 years on heating element
FFI (939)	1 year* and 5 years on heating element
CLI (941)	1 year* and 5 years on heating element
WCZ (950)	1 year* and 1 year on heating element
All Other Product Lines	18 months from the date of shipment from Brasch factory, or 12 months from the date the product is first placed into service, whichever period lapses first.

We have the experience and expertise to provide you with the personalized support to arrive at customized solutions.

Email sales@braschmfg.com
or call 314.333.5531
to find your nearest
Brasch representative.



Quality Products
produced by great
people.