

ASPEQ

HEATING GROUP

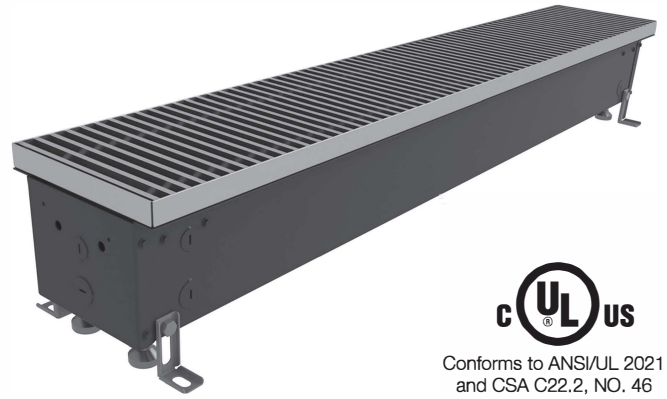

Conforms to ANSI/UL 2021
and CSA C22.2, NO. 46

943 Series Floor Trench Convector

Installation, Operation & Maintenance Instructions

GENERAL

This heater is designed to provide years of efficient, trouble free operation as a primary or supplemental heat source for comfort heating in commercial applications. Installation or use of this product in any manner not described within this manual will void the warranty and could result in injury, damage to property, or permanent damage to the heater.

Table A – 943BB OR 943HB (one element)

Catalog Number	Length "L" (ft)	Watts per foot	Total Watts	Amperage		
				208 VAC	240 VAC	277 VAC
02188	2	188	376	1.9	1.6	1.4
02250		250	500	2.4	2.1	1.8
03188	3	188	564	2.7	2.4	2.0
03250		250	750	3.6	3.1	2.7
04188	4	188	752	3.6	3.1	2.7
04250		250	1000	4.8	4.2	3.6
05188	5	188	940	4.5	3.9	3.4
05250		250	1250	6.0	5.2	4.5

IMPORTANT INSTRUCTIONS



WARNING



WHEN USING ELECTRIC APPLIANCES, BASIC PRECAUTIONS SHOULD ALWAYS BE FOLLOWED TO REDUCE THE RISK OF FIRE, ELECTRIC SHOCK, AND INJURY TO PERSONS.

1. Read all instructions before installing or using this heater.
2. A heater has hot and arcing or sparking parts inside. Do not use in areas where gasoline or flammable liquids are used or stored.
3. This heater is hot when in use. To avoid burns, do not let bare skin touch hot surfaces. Keep combustible materials, such as furniture, pillows, bedding, papers, clothes, etc. and curtains away from heater. Curtain should be at least 1 foot (305mm) minimum above heater.
4. To prevent a possible fire, do not block air intakes or exhaust in any manner.
5. Do not insert or allow foreign objects to enter any ventilation or exhaust opening as this may cause an electric shock, fire, or damage the heater.
6. Serious injury or death could result from electric shock. Verify the electrical power supply energizing the heater is disconnected at the main disconnect or service panel before installing or servicing this heater.
7. Do not operate any heater after it malfunctions. Disconnect power at service panel and have heater inspected by a reputable electrician before reusing.
8. Do not use outdoors.
9. To disconnect heater, turn controls to off, and turn off power to heater circuit at main disconnect panel (or operate internal disconnect switch if provided).
10. Use this heater only as described in this manual. Any other use not recommended by the manufacturer may cause fire, electric shock, or injury to persons.

SAVE THESE INSTRUCTIONS

FLUSH MOUNT DIMENSIONS

Measurements				
Size	2 ft.	3 ft.	4 ft.	5 ft.
Length	24 " (613mm)	36 " (918mm)	48 " (1,223mm)	60 " (1,528mm)
Grille Width	7 " (200mm)			
Cabinet Width	6 " (156mm)			
Depth	6 " (156mm)			
A - Diameter (Nested)	" (")			
B - Diameter	"			
Leveling Leg Max Adjustment	1-2" (26-52mm)			

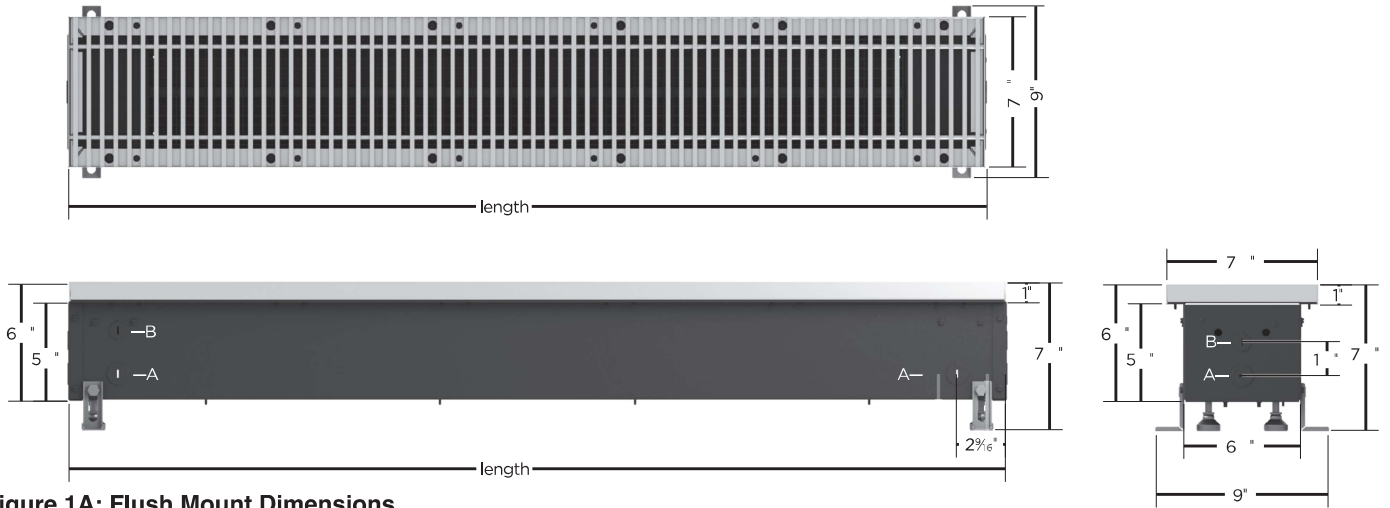

Figure 1A: Flush Mount Dimensions

SURFACE MOUNT DIMENSIONS

Measurements				
Size	2 ft.	3 ft.	4 ft.	5 ft.
Length	26 " (664mm)	38 " (969mm)	50 " (1,273mm)	62 " (1,578mm)
Grille Width	9 " (251mm)			
Cabinet Width	6 " (156mm)			
Depth	6 " (156mm)			
A - Diameter (Nested)	" (")			
B - Diameter	"			
Leveling Leg Max Adjustment	1-2" (26-52mm)			

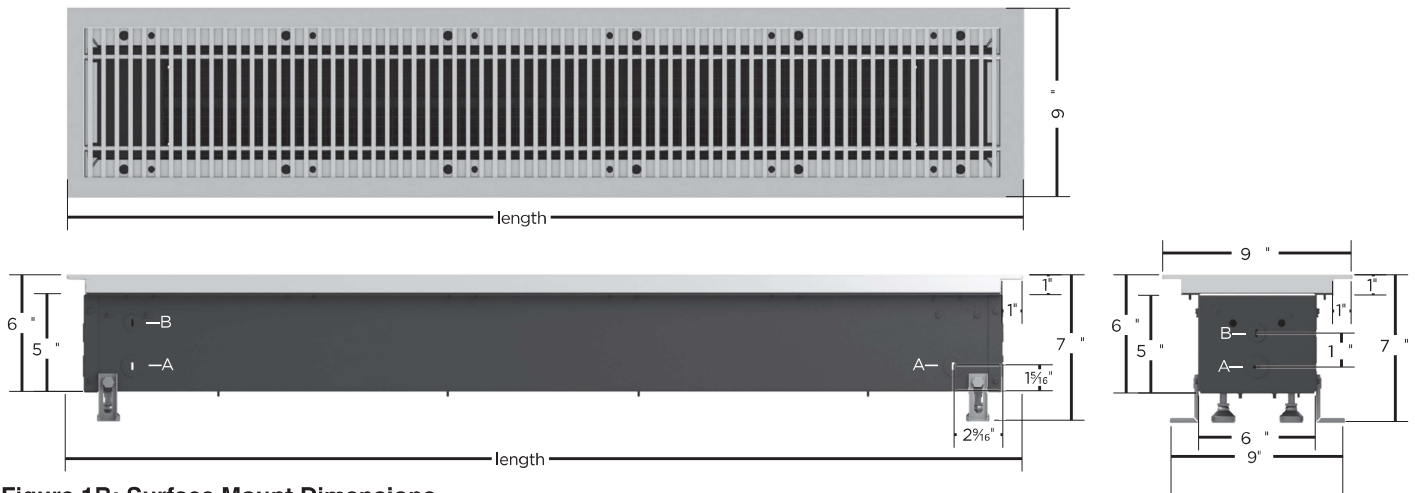

Figure 1B: Surface Mount Dimensions

INSTALLATION INSTRUCTIONS

⚠ WARNING ⚠

TO REDUCE THE RISK OF FIRE AND ELECTRIC SHOCK OR INJURY TO PERSONS, OBSERVE THE FOLLOWING:

1. Serious injury or death could result from electric shock. Verify the electrical power supply energizing the heater is disconnected at the main disconnect or service panel before installing this heater.
2. Wiring procedures and connections must be in accordance with the National Electrical Code (NEC) and local codes. Refer to Wiring Diagram located on the inside of the air inlet on heater. One of the options is shown in Figure 2. Make sure all electrical connections are tight to prevent possible overheating. Use Copper Supply Wire Only. Use wire knockout connectors to secure and protect wires.
3. Verify the electrical power supply voltage matches the voltage rating as printed on the heater nameplate. Nameplate is adjacent to the wiring diagram.

CAUTION – Never connect a heater to a voltage greater than the nameplate voltage as this will damage the heater and could cause a fire.

4. Do not install the heater against combustible low-density cellulose fiberboard surfaces, against or below vinyl wall coverings, or below any materials that may be damaged by heat such as vinyl or plastic blinds, curtains, etc.
5. Do not install heater below an electrical convenience receptacle (outlet).
6. **CAUTION** – Heater operates at high temperatures. Keep electrical cords (including telephone and computer cables), drapes, and other furnishings away from heater. For efficient and safe operation, we recommend maintaining a minimum of 12 inches (305 mm) clearance above and around the heater at all times. See Figure 1b for minimum clearance requirements.
7. To reduce the risk of fire, do not store or use gasoline or other flammable vapors or liquids in the vicinity of the heater.
8. Do not install heater in any position other than as shown in this manual.
9. Do not install in walls or ceiling. This product is for in-floor use only.
10. When mounting heater, use care when drilling mounting holes and mounting heater to building structure to avoid damaging internal heater components. Be sure to loosen mounting screws ½ turn to allow for expansion and contraction.
11. Do not remove or bypass the safety limit controls (thermal protector or manual reset) as this could allow the heater to become a fire hazard. See heater wiring diagram supplied with heater.
12. The factory-installed wires are used to connect multiple units and/or the built-in controls. Limit the maximum current to no more than 30 total amps. Refer to instructions and current capacity rating as provided with any accessories.
13. When the Transformer Relay Accessory is used in this heater, all wiring within compartment where this device is installed must be rated at least 90°C.
14. Do not allow any object to be placed on top of heater as it may be damaged or create a fire hazard.
15. Before energizing, make sure grille is secured in place along the entire length of the heater, see figure 9. Do not operate heater without grille installed.

Installation Clearances:

For safe and efficient operation, maintain at least the following minimum clearances at all times:

All sides of the heater must have 6" of clearance to wall, minimum. **Note:** element side of heater is intended to be closest to the window. See figure 2A.

Top of Heater to Bottom of Drapes Above Heater:

- Minimum 12 inches (305 mm)
- Top of Heater to be installed flush to the floor surface
- Heater has top inlet/top exhaust and is approved for 250 watts per foot.

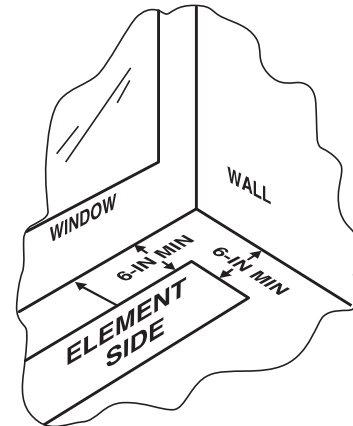

Figure 2A: Clearance to Wall/Window

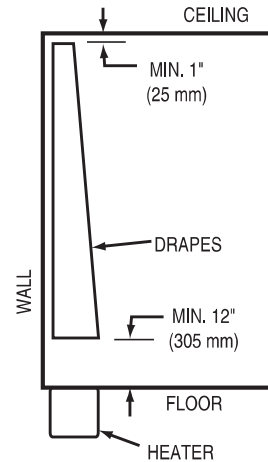

Figure 2B: Clearance for Drapery

Field Wiring – Restrictions

Copper wire size 90°C	Max. No. wire installed in wireway	Maximum Allowable Current (amps)		
		Up to 3 conductors	4 to 6 conductors	7 to 9 conductors
No. 12 AWG	9	12.3	9.8	8.6
No. 10 AWG	8	16.4	13.1	11.5
No. 8 AWG	4	22.6	18	-

Table B: Sizing Field Installed Wiring

Note: refer to National and local electrical codes to finalize wiring requirements.

Watts per Foot of Heaters	Maximum allowable length of heater run in feet (meters)	
	208 VAC 1 Ph	277 VAC 1 Ph
188	33 (10)	42 (12.8)
250	25 (7.6)	33 (10)

Table C: Maximum Length of Heater Run (based on a 30 amp feeder breaker)

Field Wiring-Rough In

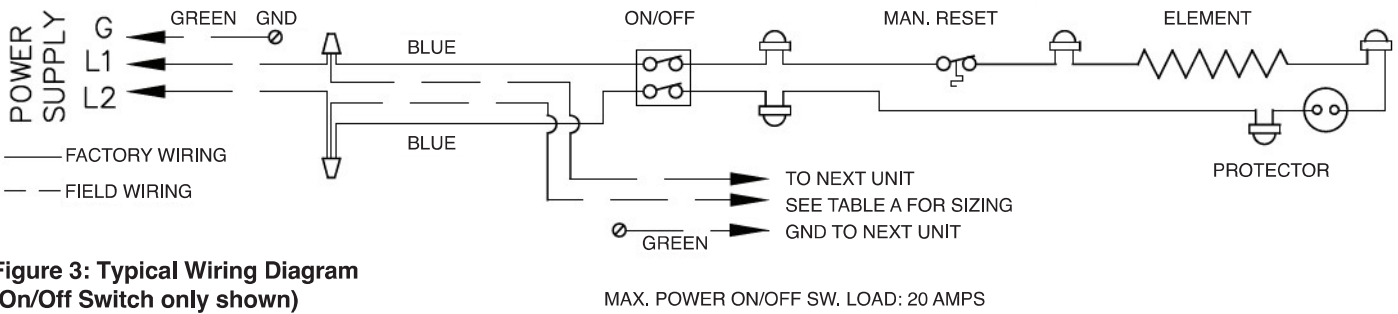

Figure 3: Typical Wiring Diagram (On/Off Switch only shown)

NOTE: Be sure to refer to the wiring diagram attached to the specific heater.

- Run branch circuit of proper voltage and wire size to location of left or right (future) junction box as indicated on heater wiring diagram – example in Fig.3. Heaters are prewired for connection to branch circuit at one end only (refer to heater wiring diagram). However, heater can be wired from opposite end by running wires through heater wire way. See Figures 4A & 4B for knockout locations.
 - "A" labeled knockouts: Nested 1/2" and 3/4" Diameters
 - "B" Labeled knockouts: 1/2" Diameter
- If it is necessary to run wires through the heater wire way, use Table B to size the field installed wiring.
- The field installed wires in the heater wire way can be loaded up to 30 amps. Refer to Table C for maximum length of heater run when the heaters are connected in parallel.

NOTE: For mix of watt densities, calculate amp draw. Do not exceed 30 amps.

- Standard 90°C minimum wiring must be used in junction boxes, wire ways, blank sections, filler sections and corner sections.
- The following control accessories are available, factory installation only, and should be accounted for during rough-in, if used:
 - For installs requiring localized unit shut off for servicing, maintenance, and other control needs: ON/OFF Switch: 20 amps @ 208-277 VAC
 - For Remote Thermostats: Transformer Relay: 25 amps @ 240 VAC, 22 amps @ 277 VAC
 - For BMS or EMS Connection: Power Relay: 25 amps @ 208-277 VAC, low voltage or line voltage

NOTE: The relays are attached to a removable plate. Follow the wiring diagram secured to the heater to make the electrical connections. Be sure to return the relay, plate, splash cover and grille assembly as previously secured.

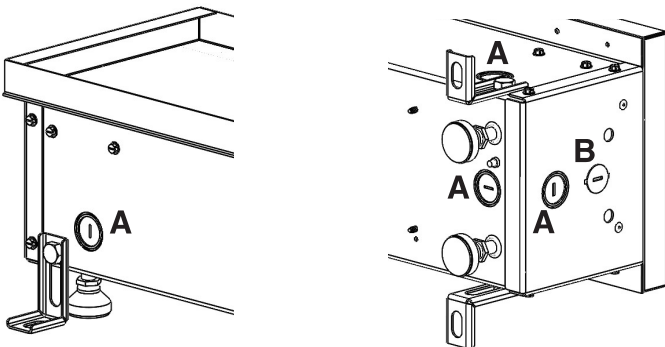

Figure 4A: Knockout Locations

Mounting – Unit Pre-Check

Refer to heating plans for exact room arrangement of heaters.

Check the heater section dimensions and the additional wall length required for a seamless, continuous run with blank sections before starting wall-to-wall type installation. Be certain all heaters and accessories needed are at hand and are of correct finish.

Mounting – Restrictions

- Units are for in-floor use only – reference Fig. 2A
- Rear long edge must be 6" from wall/window, minimum.
- Side short edge must be 6" from wall/window, minimum.
- The unit is available in two types of trims:
 - Flush-mount: trim package must be flush with flooring. Floor may be brought to edge of unit, recommended.
 - Surface Mount: trim package may rest on top of flooring, including carpeting and linoleum. See Figure 5B.

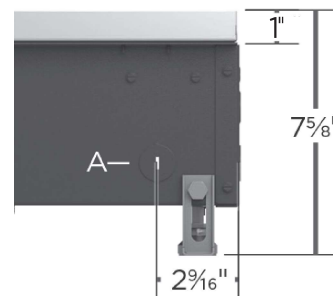
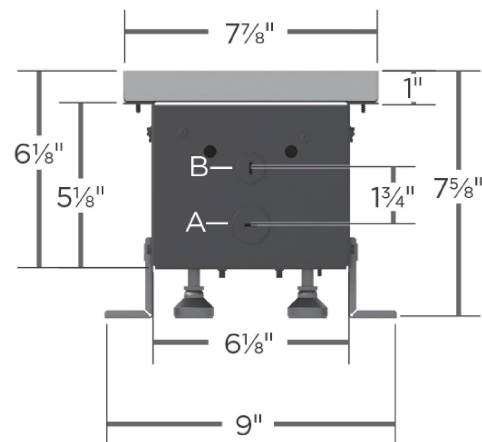

Figure 4B: Knockout Dimensions

INSTALLATION OF A SINGLE UNIT

NOTES:

- A. Below is an example of the 3 types of installations available for this unit. For a detailed, step-by-step list, please reference the end of this manual.
- B. For ease of installation, it is important that the sequence indicated below be followed in order. Blank and corner sections will install similarly.

Frame Mounted

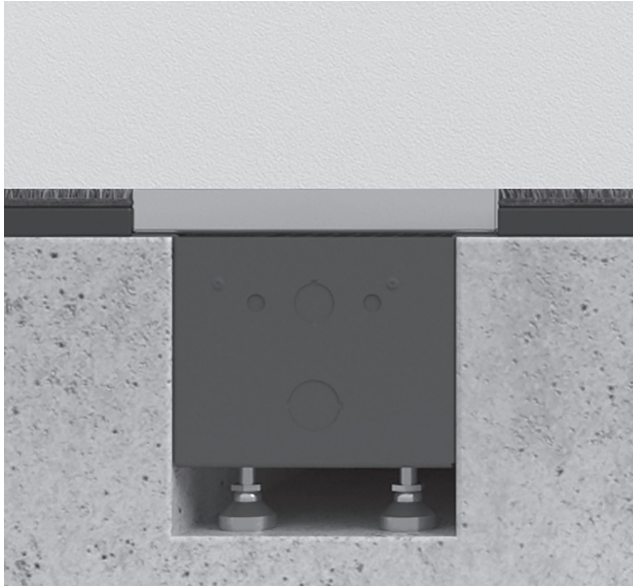

Figure 5A: Frame Mounted – Flush Grille

NOTE: Prior to unit installation, a field constructed frame must be installed. Frame material from field.

NOTE: Reference Fig. 1A & 1B for dimensions to consider during installation.

1. Remove heater from carton and discard packing pads and plastic wrap. – set grille assembly aside, temporarily.
2. Remove appropriate electrical knockouts from either end cap, side or bottom. See Figures 4A & 4B for location of knockouts.
3. Remove construction cover, splash covers (see Fig. 6A & 6B) and protective barriers to access wiring compartments, as well as swivel leveling legs and adjust until unit is level and to proper height (if used).
4. Place unit on frame in intended location, secure to frame via mounting holes provided. Reference Fig. 6D for hole locations.
5. Perform necessary wiring connections, per respective wiring diagram. Use wire knockout connectors to secure and protect wires.
6. Reinstall protective barriers, splash covers and construction cover.
7. If ready to operate and construction is complete, replace construction cover with architectural grille and fasten grille assembly to unit assembly with screws provided from construction cover.
8. Continue to Operational section for instructions.

Concrete Pour

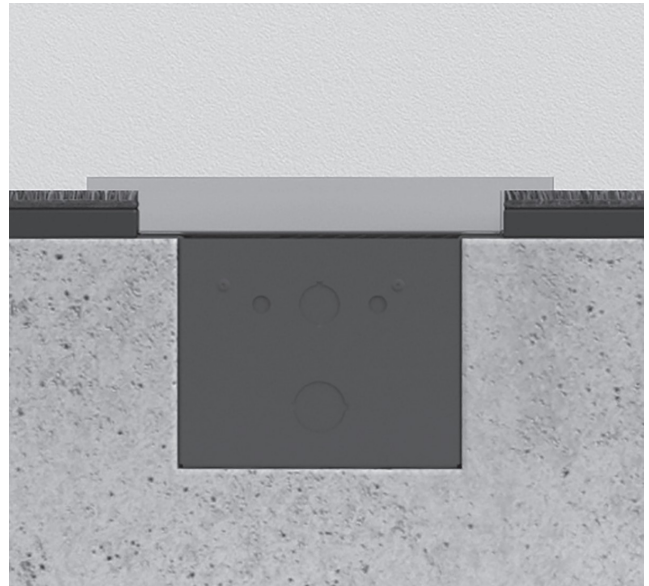

Figure 5B: Concrete Pour – Surface Grille

NOTE: Prior to unit installation, reference Fig. 1A & 1B for dimensions to consider during installation.

1. Remove heater from carton and discard packing pads and plastic wrap. Set grille assembly aside, temporarily.
2. Check floor for evenness. No minimum floor evenness is required for operation. However, an uneven floor will adversely affect appearance of installed heater.
3. Remove appropriate electrical knockouts from either end cap, side or bottom. See Figures 4A & 4B for location of knockouts.
4. Remove construction cover, splash covers (see Fig. 6A & 6B) and protective barriers to access wiring compartments.5. Place unit in intended location, adjust leveling legs.
6. Adjust mounting sliding legs and fasten to surface to secure unit.
7. Perform necessary wiring connections, per respective wiring diagram. Use wire knockout connectors to secure and protect wires.
8. Reinstall protective barriers, splash covers and construction cover.
9. Plug / cover all unused holes – i.e cover with duct tape.
10. Carefully pour concrete around unit so as not to shift or bend mounting legs.
 - a. If surface mounting, pour concrete to top of junction box region.
 - b. If flush mounting pour, concrete to top edge of grille region.
11. If ready to operate and construction is complete, replace construction cover with architectural grille and fasten grille assembly to unit assembly with screws provided.
12. Continue to Operational section for instructions.

Supporting Installation Figures

Direct on Sub Floor – with Leveling Legs

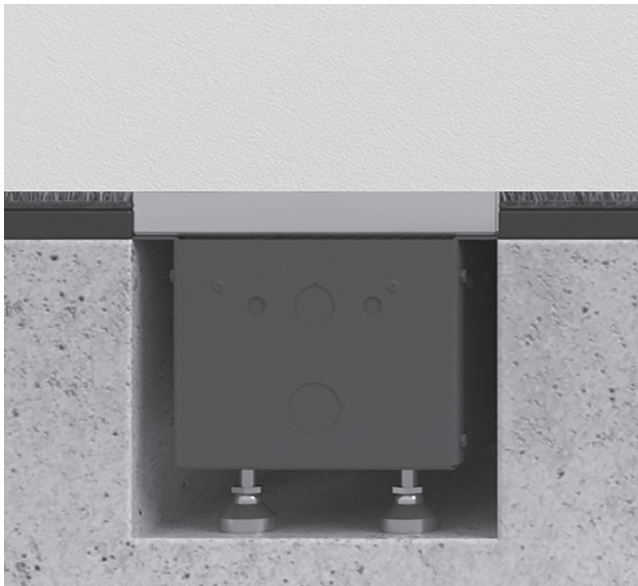

Figure 5C: Direct Floor Mount – Flush Grille

NOTE: Prior to unit installation, reference Fig. 1A & 1B for dimensions to consider during installation.

1. Remove heater from carton and discard packing pads and plastic wrap. Set grille assembly aside, temporarily.
2. Check floor for evenness. No minimum floor evenness is required for operation. However, an uneven floor will adversely affect appearance of installed heater.
3. Remove appropriate electrical knockouts from either end cap, side or bottom. See Figures 4A & 4B for location of knockouts.
4. Remove construction cover, splash covers (see Fig. 6A & 6B) and protective barriers to access wiring compartments, as well as swivel leveling legs and adjust until unit is level and to proper height
5. Place unit in intended location, adjust leveling legs so that finished floor aligned with top of unit.
 - a. Unit is recommended to be field secured.
6. Adjust mounting sliding legs and fasten to surface to secure unit – if used.
7. Perform necessary wiring connections, per respective wiring diagram. Use wire knockout connectors to secure and protect wires.
8. Reinstall protective barriers, splash covers and construction cover.
9. If ready to operate and construction is complete, replace construction cover with architectural grille and fasten grille assembly to unit assembly with screws provided.
10. Continue to Operational section for instructions.

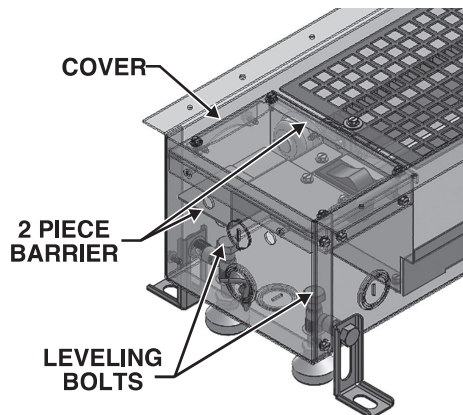

Figure 6A: Wiring Compartment Components

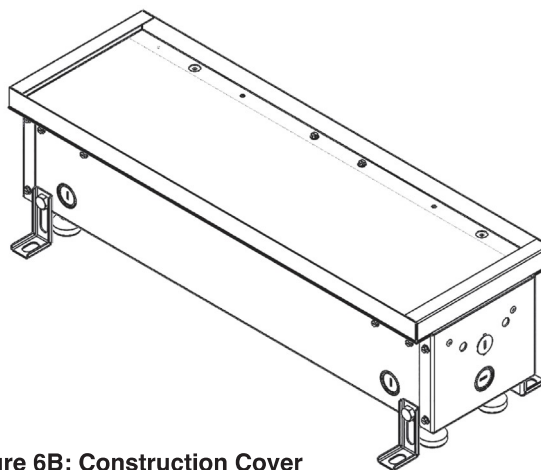

Figure 6B: Construction Cover

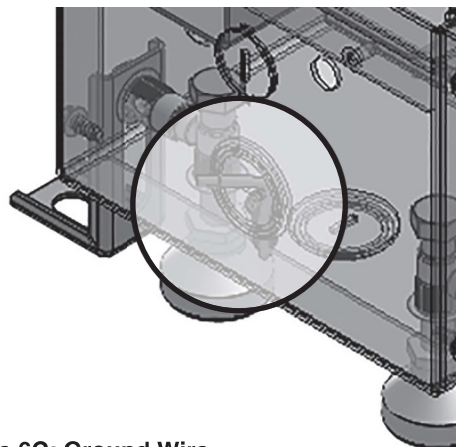

Figure 6C: Ground Wire

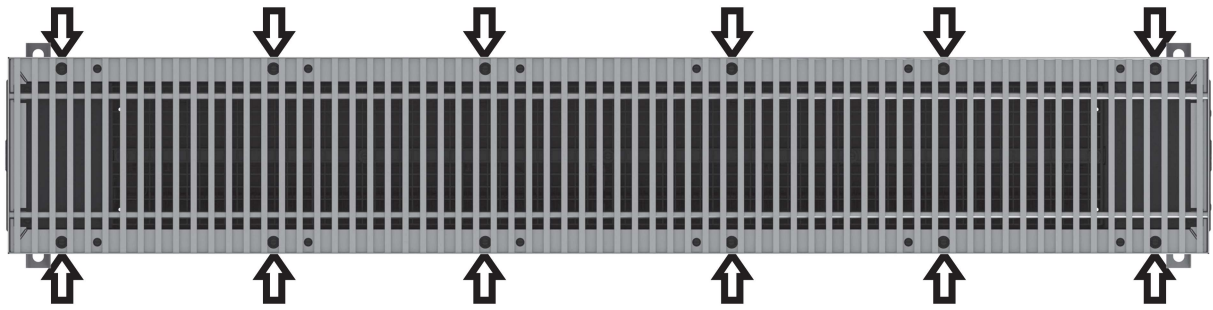

Figure 6D: Attachment for grille assembly

Wiring

1. With supply power off, locate the wiring diagram on the heater.
The heater diagram is specific for the model.
2. Units on/off switch only skip to step 11 a-e
3. Unit with power relay skip to step 12 a-d.
4. Unit with transformer relay skip to 13 a-e.
5. Turn on supply power to the heater and put the on/off switch in the ON position. **Note:** make sure the field supplied Controls are supplying voltage to the heater. Once the control calls for heat, you should feel heat within a minute.
6. With everything confirmed, turn the supply power off at the breaker.
7. Reinstall junction box covers.
8. Install grille assembly with the six provided screws.
9. Turn on the supply power and make sure the heater is operating normal.
- 10. On/Off Switch Only**
 - a. Locate the green ground wire and two blue wires on the on/off switch. Remove the wire nuts from the blue wires.
 - b. Locate the field-supplied wires. Wire field ground wire to the green ground wire in the junction box.
 - c. Wire field Line 1 wire to one blue wire on the on/off switch.
 - d. Wire field line 2 or Neutral wire to the remaining blue wire on the on/off switch.
 - e. With all connections made make sure connections are secure, reinstall on/off switch brackets and make sure the on/off switch is in the OFF position.
 - f. Go back to steps 5 through 10.
- 11. Power Relay**
 - a. Locate the power relay. **Note:** label will be on junction box cover.
 - b. Depending on model, the relay holding coil is available in 24V, 120V, and 277-208V. Verify correct control voltage.
 - c. Remove the junction box cover. The relay is on a bracket and can be removed from the junction box for wiring. Take care not to damage relay wire.
 - d. Wire control voltage wiring between the red and blue wires on the relay.
 - e. Make sure connections are secure and reinstall relay in junction box.
 - f. Go back to steps 5 through 10.
- 12. Transformer Relay**
 - a. Locate transformer relay. **Note:** label will be on junction box cover.
 - b. The transformer relay will step heater line voltage down to 24V for a low voltage wall thermostat (field supplied).
 - c. Remove the junction box cover. The transformer relay is on a bracket and can be removed from the junction box for wiring. Take care not to damage transformer relay wires.
 - d. Wire thermostat wiring between the red and white wires on the transformer relay.
 - e. Go back to steps 5 through 10.

INSTALLATION OF MULTIPLE UNITS

NOTE: Directions below assume that the units will be connected in parallel and fed from a single supply breaker connected to one unit. If not, follow directions for installation of a single unit. **DO NOT CONNECT MULTIPLE UNITS IN SERIES AS THEY WILL NOT GENERATE NAMEPLATE WATTAGE.**

NOTE: For ease of installation, it is important that the sequence indicated below be followed in order. Blank and corner sections will install similarly.

NOTE: Prior to unit installation, reference Fig. 1A & 1B for dimensions to consider during installation

1. Remove heater from carton and discard packing pads and plastic wrap. – set grille assembly aside, temporarily.
2. Check floor for evenness. No minimum floor evenness is required for operation. However, an uneven floor will adversely affect appearance of installed heater.
3. Remove appropriate electrical knockouts from either end cap, side or bottom. See Figures 4A & 4B for location of knockouts.
4. Remove construction cover, splash covers (see Fig. 6A & 6B) and protective barriers to access wiring compartments, as well as swivel leveling legs and adjust until unit is level and to proper height
5. Size the field installed wiring using Table B, **OR** use Table C to determine the maximum length of heater run possible using the field installed wiring in the heater wire way.
6. If corner sections or blanks are to be used, consult accessory installation instructions.
7. Place heaters in mounting positions and check for evenness of floor – per “Individual Installation” instructions from above.
8. Perform necessary wiring connections, per respective wiring diagram. Use wire knockout connectors to secure and protect wires.
9. Mount the heaters in the floor using screws, bolts, or anchors (by installer) which suit the floor construction. Alignment bolts (from factory) can be inserted in adjoining end corners of housings to maintain alignment between units. See Figures 7A, 7B, & 7C for details.
10. Ground the heater at each end of the string using the ground wire provided. Connect adjacent heaters with a jumper ground wire (by installer), ensuring good metal-to-metal contact at both ends.
11. Reinstall protective barriers, splash covers and construction cover.
12. If ready to operate and construction is complete, replace construction covers with architectural grilles and fasten grille assembly to unit assembly with screws provided.

Blank Sections and Corners

1. Blank sections and corners are installed in the same manner as heater units.
2. Note that wiring may need to run through a blank section if it is installed in a multiple unit run.
3. Blank sections and corners must be leveled and grounded comparable to heater units.

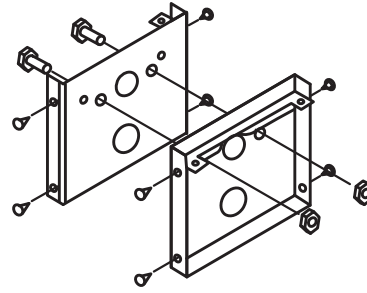

Figure 7A: End-to-End Connection

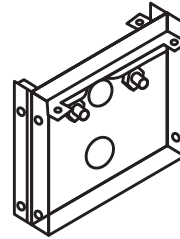

Figure 7B: Completed End Connection

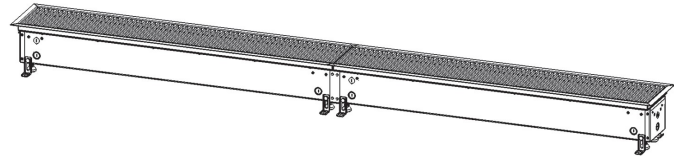

Figure 7C: Completed Assembly (showing all leg options)

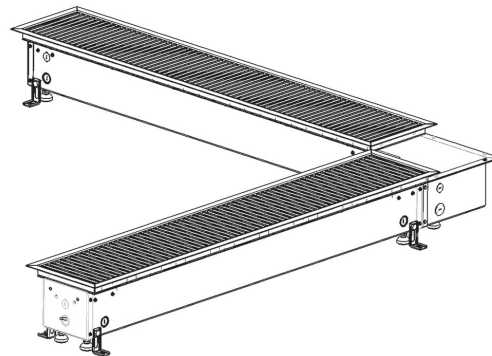

Figure 7D: Completed Assembly (showing corner option)

OPERATING INSTRUCTIONS

1. The heater should be properly installed prior to use.
2. After heater is completely assembled and installed, set operating controls to NO HEAT and energize the heater circuit. Verify the heater is not producing heat.
3. Adjust operating control to call for heat. Allow heater to operate for a few minutes and verify all units are producing heat.

NOTE: During initial startup, heaters may produce an odor and a slight amount of smoke from the manufacturing residues on the heating element. Allow heaters to operate for 30 minutes to dissipate these residues. Ventilating the area may be desired.

4. To set operating controls to maintain desired comfort level, allow heaters to operate until room ambient temperature reaches the desired level. The operating control can then be adjusted to maintain this temperature.
5. Do not tamper with any of the control devices.
6. Servicing should be performed by an authorized service representative.

NOTE: When the on/off switch (rocker type) is provided (see Fig. 8), it can be accessed by removing the grill assembly, cover plate and the splash cover under which it is located. The splash cover bears a label identifying the on/off switch location.

IMPORTANT NOTE: These heaters are provided with a built-in safety limit to automatically turn off the heater if it is blocked or otherwise overheats. The heaters should not be cycling off because of safety limit activation during normal use. If this is occurring, check heater installation to assure it has adequate clearances and free airflow around the heater is not restricted. Verify that the heater is free of debris. If heater continues to cycle on this safety control, discontinue using it until it can be inspected and/or repaired by a qualified electrician.

MANUAL RESET: These heaters are also provided with a manual reset safety limit (see Fig. 8) to automatically turn off the heater. This is similar to the Thermal Protector, but will require a manual press of a button to allow the heater to regain function. If the unit is not producing heat, verify the heater is free of debris or major airflow restrictions. It is recommended that the circuit breaker be turned off prior to performing the manual reset. To access the manual reset button, remove the grille assembly and the splash cover under which it is located. The splash cover bears a label identifying the manual reset location. The button is located at the center of the body of the manual reset safety limit. Be sure to return the splash cover and grille assembly as previously secured before applying power to the unit.

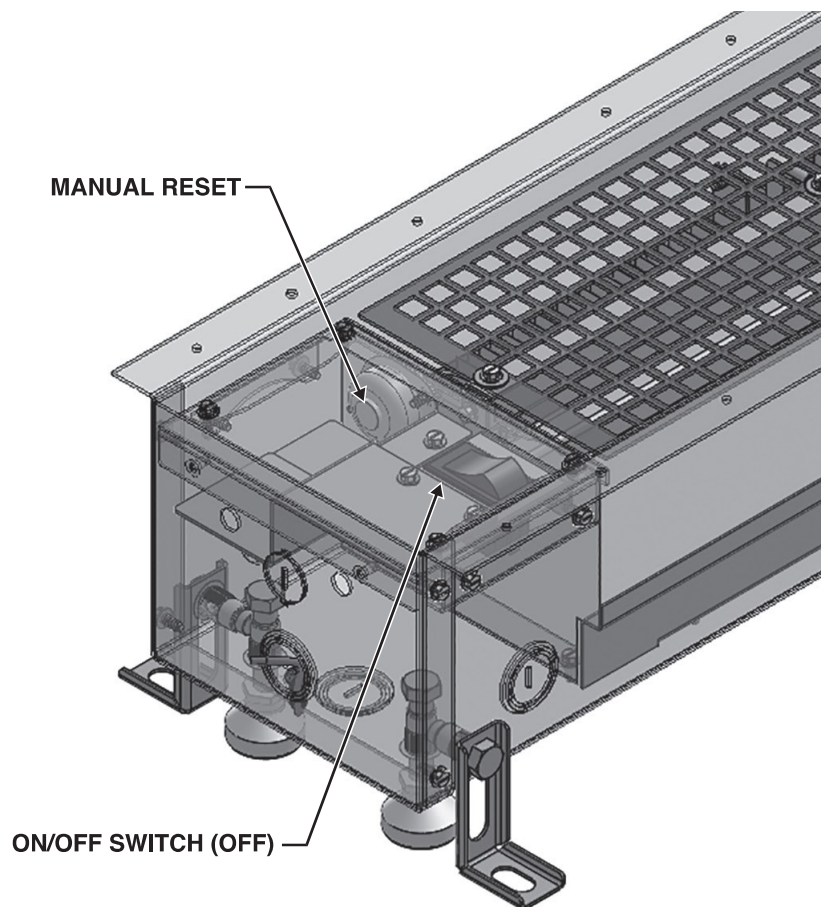

Figure 8: Left Junction Box

MAINTENANCE INSTRUCTIONS

Your heater will give you years of service and comfort with only minimal care. The user can perform periodic cleaning of the exterior cabinet but all other interior cleaning and servicing should be done by a qualified service person.

As air moves through the heater by convection, dust and lint may accumulate in the heater and around the heating element. Some small debris may also fall through the top mesh. It is recommended that your heater be cleaned internally and inspected for damage at least annually, or as needed.

1. The exterior of the heater may be cleaned with a damp cloth. Do not use harsh cleaners, polishes, or waxes as these may damage the surface or leave a residue that will discolor.
2. Cleaning the interior of the heater will require removing the grille assembly.
3. With grille assembly removed, a vacuum cleaner or compressed air may be used to clear dust, lint, and small debris from inside heater and around the element. Use care not to damage aluminum fins.
4. As a matter of normal maintenance, remove both splash covers and check remainder of heater for damage or possible maintenance issues. Make repairs as needed.
5. Replace grille assembly.
6. Restore power to heater and verify operation per Operating Instructions steps 1 through 3.

⚠ WARNING ⚠

1. SERIOUS INJURY OR DEATH COULD RESULT FROM ELECTRIC SHOCK. THESE STEPS SHOULD ONLY BE PERFORMED BY A QUALIFIED SERVICE PERSON. VERIFY ALL ELECTRICAL POWER SUPPLIES COMING TO HEATER ARE DISCONNECTED AT MAIN DISCONNECT OR SERVICE PANEL BEFORE SERVICING HEATER.

NOTE: MORE THAN ONE POWER SOURCE MAY ENTER HEATER.

2. ALLOW HEATER TO COOL BEFORE CLEANING TO PREVENT A POSSIBLE BURN.

3. USE CARE WHEN CLEANING ELEMENT FINNS. FINNS ARE SHARP AND MAY CAUSE CUTS. AVOID SKIN CONTACT.

Table D: Service Parts List

943 SERIES FLOOR DROP-IN CONVECTOR							
ELEMENTS							
2 FOOT 188W/FT		2 FOOT 250W/FT		3 FOOT 188W/FT		3 FOOT 250W/FT	
208V	1802-2001-039	208V	1802-2001-198	208V	1802-2001-008	208V	1802-2001-009
240V	1802-2001-040	240V	1802-2001-099	240V	1802-2001-007	240V	1802-2001-008
277V	1802-2001-041	277V	1802-2001-200	277V	1802-2001-006	277V	1802-2001-007
4 FOOT 188W/FT		4 FOOT 250W/FT		5 FOOT 188W/FT		5 FOOT 250W/FT	
208V	1802-2001-014	208V	1802-2001-015	208V	1802-2001-020	208V	1802-2001-021
240V	1802-2001-013	240V	1802-2001-014	240V	1802-2001-019	240V	1802-2001-020
277V	1802-2001-012	277V	1802-2001-013	277V	1802-2001-018	277V	1802-2001-019

GRILLE							
2 FOOT FLUSH		2 FOOT SURFACE		3 FOOT FLUSH		3 FOOT SURFACE	
ALUMINUM	2501-11033-001	ALUMINUM	2501-11033-005	ALUMINUM	2501-11033-002	ALUMINUM	2501-11033-006
BLACK	2501-11033-101	BLACK	2501-11033-105	BLACK	2501-11033-102	BLACK	2501-11033-106
WHITE	2501-11033-201	WHITE	2501-11033-205	WHITE	2501-11033-202	WHITE	2501-11033-206
4 FOOT FLUSH		4 FOOT SURFACE		5 FOOT FLUSH		5 FOOT SURFACE	
ALUMINUM	2501-11033-003	ALUMINUM	2501-11033-007	ALUMINUM	2501-11033-004	ALUMINUM	2501-11033-008
BLACK	2501-11033-103	BLACK	2501-11033-107	BLACK	2501-11033-104	BLACK	2501-11033-108
WHITE	2501-11033-203	WHITE	2501-11033-207	WHITE	2501-11033-204	WHITE	2501-11033-208

TRANSFORMER		TIME DELAY RELAY		
277V	208/240V	24V CONTROL	120V CONTROL	208-277V CONTROL
5108-11003-002	5108-11003-001	410171001	410171002	410171003

LINEAR LIMIT			
2 FOOT	3 FOOT	4 FOOT	5 FOOT
4520-0007-007	4520-0007-008	4520-0007-009	4520-0007-010

MANUAL RESET LIMIT			
2 FOOT	3 FOOT	4 FOOT	5 FOOT
4520-2017-000	4520-2017-000	4520-2017-001	4520-2017-001

SCREEN			
2 FOOT	3 FOOT	4 FOOT	5 FOOT
5227-11003-001	5227-11003-002	5227-11003-003	5227-11003-004

POWER ON/OFF SW
ALL MODELS
410170001

J-BOX COVER
ALL MODELS
1215-11125-000

STEP-BY-STEP INSTALLATION INSTRUCTIONS

Flush Mounted Grille Model

Direct on Sub-Floor, Leveling Feet Method

1. Carefully remove heater from packaging. Note: grille assembly packaged separate.
2. All sides of the heater must have 6" of clearance to wall, minimum. Note: element side of heater is intended to be closest to the window. See figure 9.

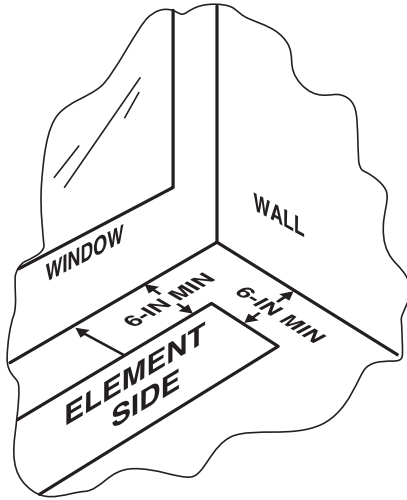

Figure 9: Installation Location

3. Determine mounting and wiring locations.
4. Carefully cut a hole the length of the heater by 8" wide into floor.
5. Fabricate a U shaped box with inside dimension of 6.5" wide and 6" high sides. (materials field supplied) See figure 10A.

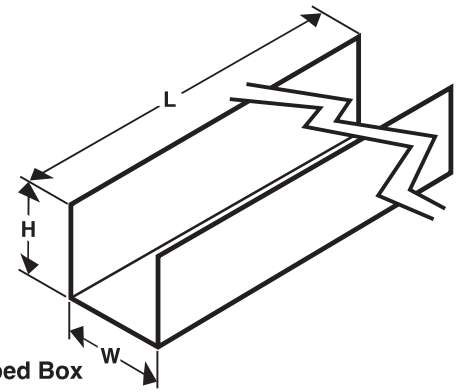

Figure 10A: U Shaped Box

6. Mount fabricated box so the bottom inside of the box is 7.5" below floor opening. See figure 10B.

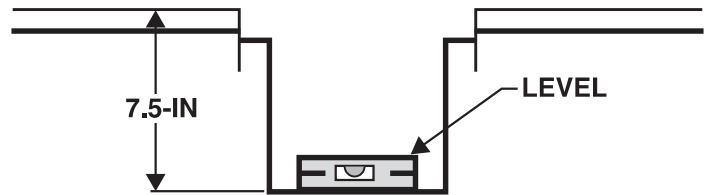

Figure 10B: U Shaped Box Mounting Depth

7. Use a level to verify the fabricated box is installed properly. See figure 10B.
8. Remove construction cover and junction box covers from the heater and remove appropriate electrical knockouts. **Note:** It is suggested to bring supply wiring in via the manual reset junction box (labeled on cover). If this is not possible, there is a wire way opposite the element in the heater box. The supply wire can be fed from the opposite junction box through the wire way. See figure 11A.

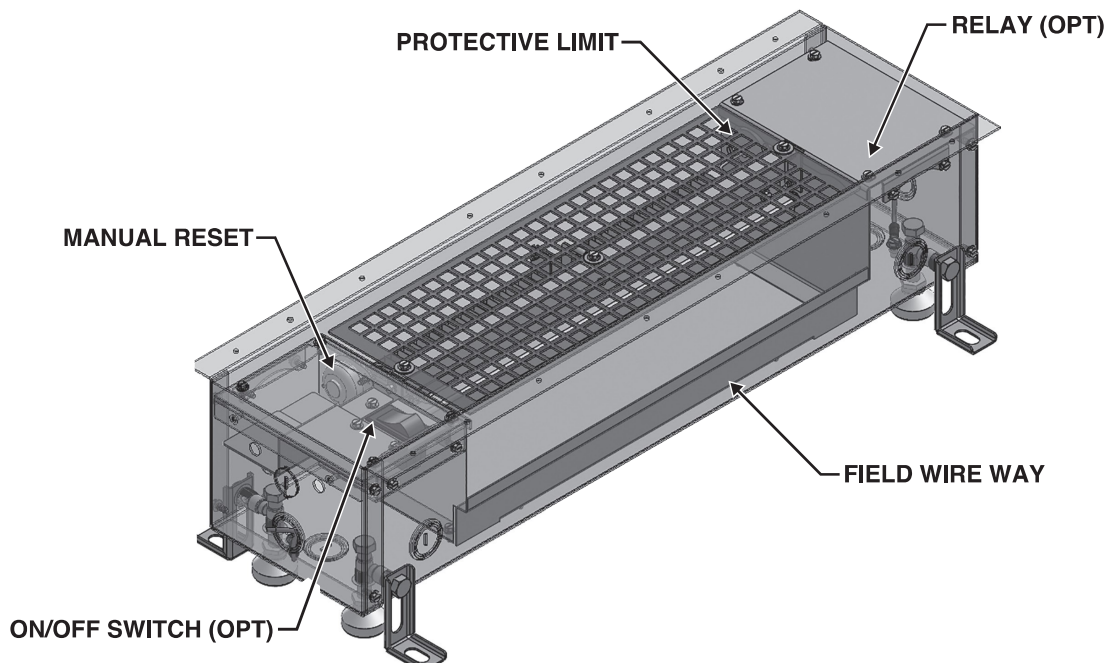

Figure 11A: Product Components

- Carefully remove two Z-shaped barriers to reach wiring and leveling feet. **Note:** depending on heater model, removal of accessories from the junction box is required for wiring purposes and leveling of the heater. See figure 11B.

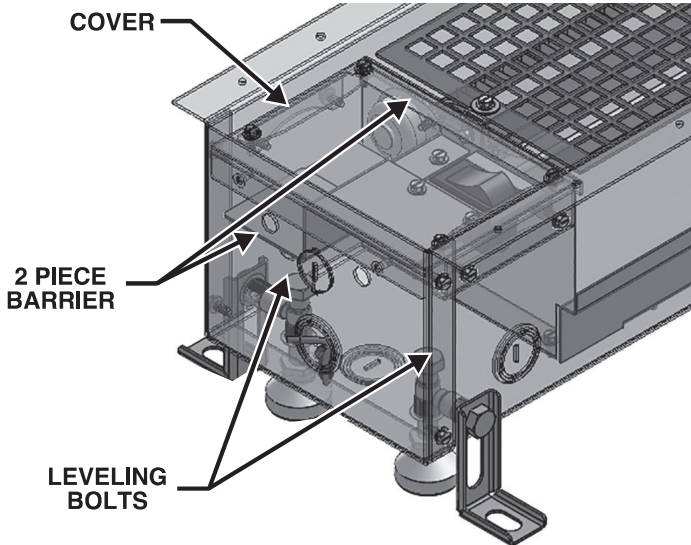

Figure 11B: Wiring Compartment Components

- Make sure supply power is off and field wiring is in proper locations.
- Insert the heater box into the fabricated box.
- Feed supply wiring into the desired knockout, leaving 6" of wire leads extending into the junction box.
- With a socket wrench and extension use a 9/16 socket to adjust leveling feet. **Note:** leave wire clamps loose as leveling. (field supplied)
- Temporarily, position construction cover or grille assembly on drop box and check with a level.
- Repeat this process until level. **Note:** the grille must be flush with floor surface. See figure 12A.

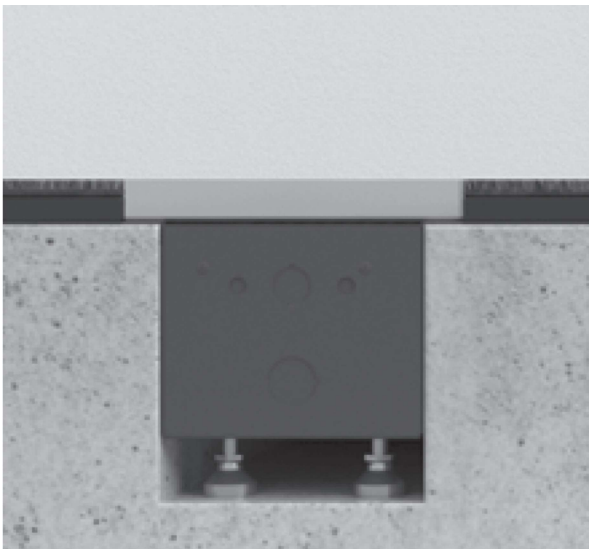

Figure 12A: Flush Mount – Grille Sits Flush to the Floor

- Remove grille assembly and tighten wire clamps.
- Continue to wiring section of instructions.

Flush Mounted Grille Model

Framed Mounted Method

- Carefully remove heater from packaging. **Note:** grille assembly is packaged separate.
- All sides of the heater must have 6" of clearance to wall, minimum. **Note:** element side of heater is intended to be closest to the window. See figure 9.
- Determine mounting and wiring locations.
- Carefully cut a hole the length of the heater by 8" wide into floor.
- Fabricate a U shaped box (materials field supplied) with inside dimension of 6.5" wide and 6" high sides. See figure 10A.
- Mount fabricated box so the bottom inside of the box is 7" below floor opening. **Note:** installing units before finish floor is installed, subtract floor thickness from 7" for mounting depth. Example: 7" mounting depth minus floor thickness .75" equals new mounting depth. See figure 10C.

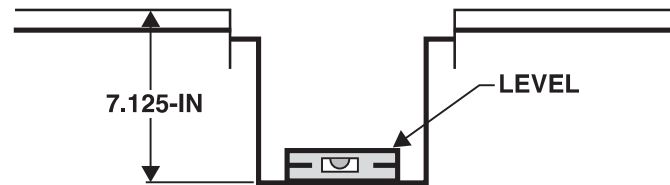

Figure 10C: U Shaped Box Depth Dimension

- Use a level to verify the fabricated box is installed properly. See figure 10C.
- Remove construction cover and junction box covers from the heater and remove appropriate electrical knockouts. **Note:** It is suggested to bring supply wiring in via the manual reset junction box (labeled on cover). If this is not possible, there is a wire way opposite the element in the heater box. The supply wire can be fed from the opposite junction box through the wire way. See figure 11A.
- Carefully remove two Z-shaped barriers to reach wiring and leveling feet. **Note:** depending on heater model, removal of accessories from the junction box is required for wiring purposes and leveling of the heater. See figure 11B.
- Make sure supply power is off and field wiring is in proper locations.
- Insert the heater box into the fabricated box.
- Feed supply wiring into the desired knockout, leaving 6" of wire leads extending into the junction box.
- Replace and secure construction cover, or use the grille assembly.
- Mount heater box to sidewalls of fabricated box through oversized holes located in construction cover. **Note:** the construction cover/grille assembly must be flush with floor surface. See figure 13.
- Remove construction cover/grille assembly.
- Continue to wiring section of instructions.

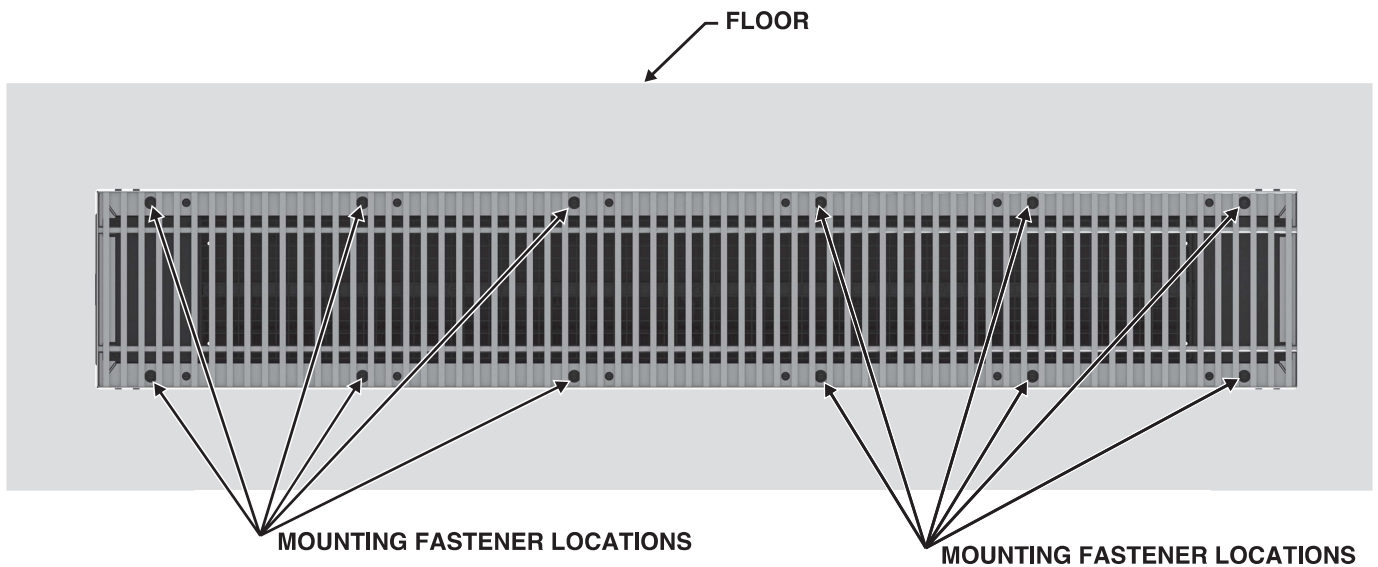

Figure 13: Mounting Fastener Locations

Surface Mount Grille Model

Direct on Sub-Floor, Leveling Feet Method

- Carefully remove heater from packaging. **Note:** grille assembly is packaged separate.
- All sides of the heater must have 6" of clearance to wall, minimum. **Note:** element side of heater is intended to be closest to the window. See figure 9.
- Determine mounting and wiring locations.
- Carefully cut a hole the length of the heater by 8" wide into floor.
- Fabricate a U shaped box (materials field supplied) with inside dimension of 6.5" wide and 6" high sides. See figure 10A.
- Mount fabricated box so the bottom inside of the box is 7.25" below floor opening. See figure 10D.
- Insert the heater box into the fabricated box.
- Feed supply wiring into the desired knockout, leaving 6" of wire leads extending into the junction box.
- With a socket wrench and extension, use a 9/16 socket to adjust leveling feet. **Note:** leave wire clamps loose during leveling. (field supplied)
- Temporarily, position construction cover or grille assembly on drop box and check with a level.
- Remove grille and adjust leveling feet so flange of grille is resting on floor surface. See figure 12B.

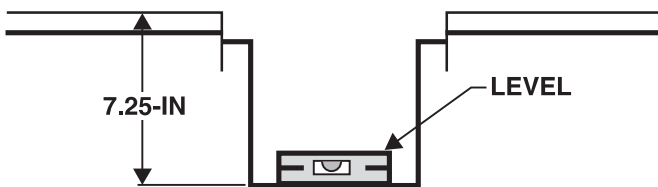

Figure 10D: U Shaped Box Depth Dimension

- Use a level to level fabricated box. See figure 10D.
- Remove construction cover and junction box covers from the heater and remove appropriate electrical knockouts. **Note:** It is suggested to bring supply wiring in via the manual reset junction box (labeled on cover). If this is not possible, there is a wire way opposite the element in the heater box. The supply wire can be fed from the opposite junction box through the wire way. See figure 11A.
- Carefully remove two Z-shaped barriers to reach wiring and leveling feet. **Note:** depending on heater model, removal of accessories from the junction box is required for wiring purposes and leveling of the heater. See figure 11B.
- Make sure supply power is off and field wiring is in proper locations.

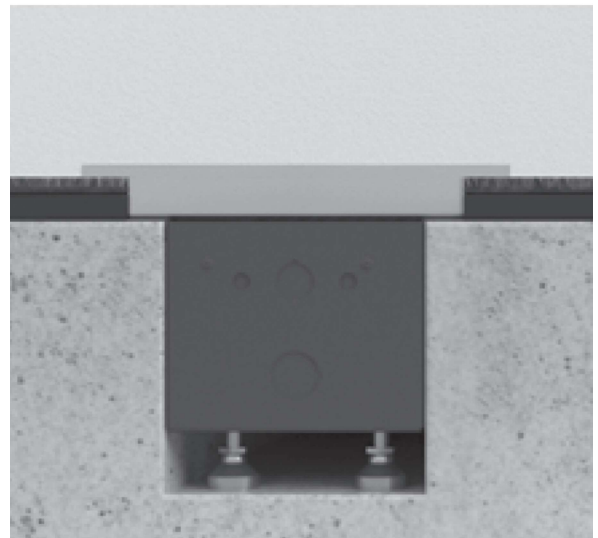

Figure 12B: Surface Mount – Grille Flange Sits on Top of Floor

- Repeat this process until level.
- Remove construction cover/grille assembly.
- Continue to wiring section of instructions.

Surface Mount Grille Model

Frame Mounted Method

1. Carefully remove heater from packaging. **Note:** grille assembly is packaged separate.
2. All sides of the heater must have 6" of clearance to wall, minimum. **Note:** element side of heater is intended to be closest to the window. See figure 9.
3. Determine mounting and wiring locations.
4. Carefully cut a hole the length of the heater by 8" wide into floor.
5. Fabricate a U shaped box (materials field supplied) with inside dimension of 6.5" wide and 6" high sides. See figure 10A.
6. Mount fabricated box so the bottom inside of the box is 7" below floor opening. **Note:** installing units before finish floor is installed, subtract floor thickness from 7" for mounting depth. **Example:** 7" mounting depth minus floor thickness .75" equals new mounting depth. See figure 10E.
7. Use a level to level fabricated box.
8. Remove construction cover and junction box from the heater and remove appropriate electrical knockouts. **Note:** It is suggested to bring supply wiring in via the manual reset junction box (labeled on cover). If this is not possible, there is a wire way opposite the element in the heater box. The supply wire can be fed from the opposite junction box through the wire way. See figure 11A.
9. Carefully remove two Z-shaped barriers to reach wiring and leveling feet. **Note:** depending on heater model, removal of accessories from the junction box is required for wiring purposes and leveling of the heater. See Figure 11B.
10. Make sure supply power is off and field wiring is in proper locations.
11. Insert the heater box into the fabricated box.
12. Feed supply wiring into the desired knockout, leaving 6" of wire leads extending into the junction box.
13. Replace and secure construction cover, or use the grille assembly.
14. Mount heater box to side walls of fabricated box through oversized holes located in grille. See figure 13.
15. Remove construction cover / grille assembly.
16. Continue to wiring section of instructions.

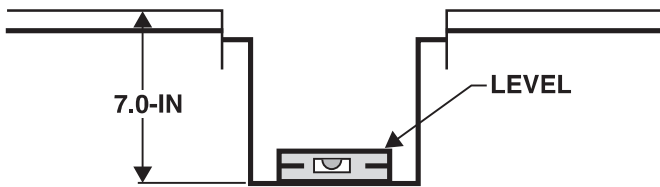

Figure 10E: U Shaped Box Depth Dimension

Slab Floors

Flush Grille and Surface Grille

- Carefully remove heater from packaging. **Note:** grille assembly is packaged separate.
- All sides of the heater must have 6" of clearance to wall, minimum. Note: element side of heater is intended to be closest to the window. See figure 9.
- Determine mounting and wiring locations.
- Box out area
 - Flush Grille: 4" longer than the length of the heater by 12" wide by 7.5" depth. (materials field supplied) See figure 10F.
 - Surface Grille: 4" longer than the length of the heater by 12" wide by 7" depth. (materials field supplied) See figure 10F.

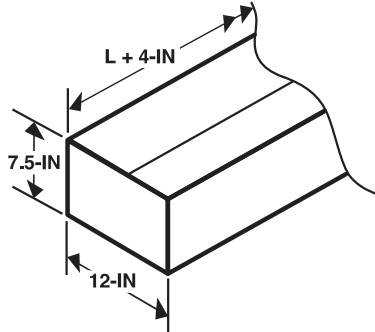

Figure 10F: Concrete Pour Framing Dimensions

- Use a level to level fabricated box in position.
- Remove construction cover and junction box covers from the heater and remove appropriate electrical knockouts. **Note:** It is suggested to bring supply wiring in via the manual reset junction box (labeled on cover). If this is not possible, there is a wire way opposite the element in the heater box. The supply wire can be fed from the opposite junction box through the wire way. See figure 11A.
- Carefully remove two Z-shaped barriers to reach wiring and leveling feet. **Note:** depending on heater model, removal of accessories from the junction box is required for wiring purposes and leveling of the heater. See Figure 11B.
- Make sure supply power is off and field wiring is in proper locations.
- Remove slide legs and hardware from parts kit - attached mounting legs to heater box loosely. See Figure 11C.

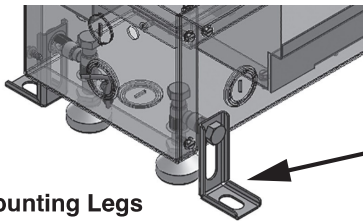

Figure 11C: Mounting Legs

- Insert the heater box into the center of fabricated box leaving 2" from each side to fabricated box. See Figure 10G.

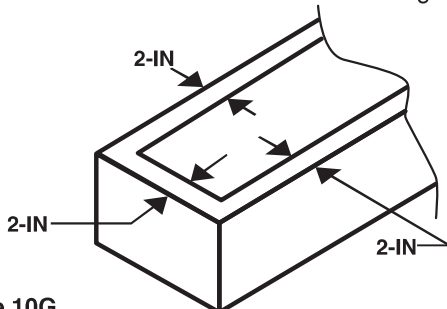

Figure 10G

- Adjust slide legs flush with subfloor mark and drill hole locations. See Figure 11C.
- With appropriate hardware, mount slide leg brackets to the subfloor (field supplied).
- Feed supply wiring into the desired knockout, leaving 6" of wire leads extending into the junction box.
- After wiring, use tape to cover and seal any access holes in junction box. See Figure 11D.

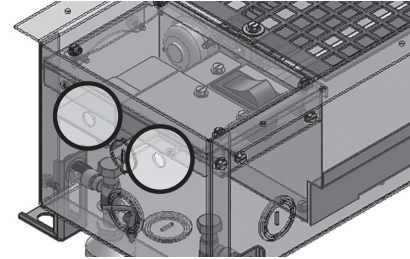

Figure 11D: Modular Connection Points

- With a socket wrench and extension, use a 9/16 socket to adjust leveling feet. Note: leave wire clamps loose during leveling (field supplied).
- Replace and secure construction cover, or use the grille assembly.
- Temporarily, position construction cover or grille assembly on heater box and check with a level making sure the grille is level and flush with floor. Note: If flooring is added later, the floor thickness has to be added so the grille will fit flush with the added flooring.
- Repeat this process until level. **Note:** the grille must be flush with floor surface. See Figure 12C (Flush Grille) or 12D Surface Grille).
- Remove grille assembly, tighten slide legs, and wire clamps. See Figure 11D.
- Use temporary cover and fill in area between heater box and fabricated box.
- Continue to wiring section of instructions.

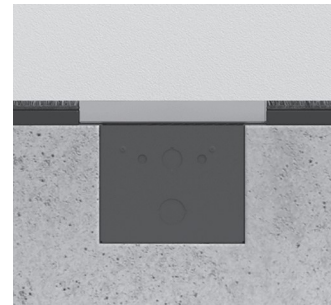

Figure 12C: Flush Grille

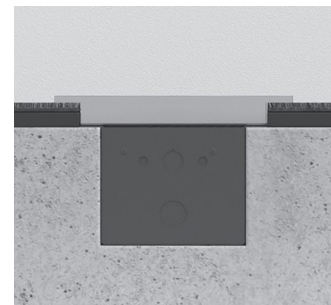

Figure 12D: Surface Grille

LIMITED WARRANTY

All products manufactured by ASPEQ Heating Group are warranted against defects in workmanship and materials for one year from the date of purchase, except heating elements which are warranted against defects in workmanship and materials for five years from date of purchase. This warranty does not apply to damage from accident, misuse, or alteration; nor where the connected voltage is more than 5% above the nameplate voltage; nor to equipment improperly installed or wired or maintained in violation of the product's installation instructions. This warranty does not apply to refurbished products. All claims for warranty work must be accompanied by proof of the date of purchase.

The customer shall be responsible for all costs incurred in the removal or reinstallation of products, including labor costs, and shipping costs incurred to return products to ASPEQ Heating Group. Within the limitations of this warranty, inoperative units should be returned to ASPEQ Heating Group, and we will repair or replace, at our option, at no charge to you with return freight paid by ASPEQ. It is agreed that such repair or replacement is the exclusive remedy available from ASPEQ Heating Group.

THE ABOVE WARRANTIES ARE IN LIEU OF ALL OTHER WARRANTIES EXPRESSED OR IMPLIED, AND ALL IMPLIED WARRANTIES OF MERCHANTABILITY AND FITNESS FOR A PARTICULAR PURPOSE WHICH EXCEED THE AFORESAID EXPRESSED WARRANTIES ARE HEREBY DISCLAIMED AND EXCLUDED FROM THIS AGREEMENT. ASPEQ HEATING GROUP SHALL NOT BE LIABLE FOR CONSEQUENTIAL DAMAGES ARISING WITH RESPECT TO THE PRODUCT, WHETHER BASED UPON NEGLIGENCE, TORT, STRICT LIABILITY, OR CONTRACT.

Some states do not allow the exclusion or limitation of incidental or consequential damages, so the above exclusion or limitation may not apply to you. This warranty gives you specific legal rights, and you may have other rights which vary from state to state.

Contact ASPEQ Heating Group in St Louis, MO, at 314-333-5550. Merchandise returned to the factory must be accompanied by a return authorization and service identification tag, both available from ASPEQ Heating Group. When requesting return authorization, include all catalog numbers shown on the products.

HOW TO OBTAIN WARRANTY SERVICE AND WARRANTY PARTS PLUS GENERAL INFORMATION

- | | |
|--------------------------------|--|
| 1. Warranty Service or Parts | 1-314-333-5550 |
| 2. General Product Information | www.aspeqheating.com |

Note: When obtaining service always have the following:

1. Model number of the product
2. Date of manufacture
3. Part number or description

ASPEQ
HEATING GROUP

St. Louis, MO 63144 USA