

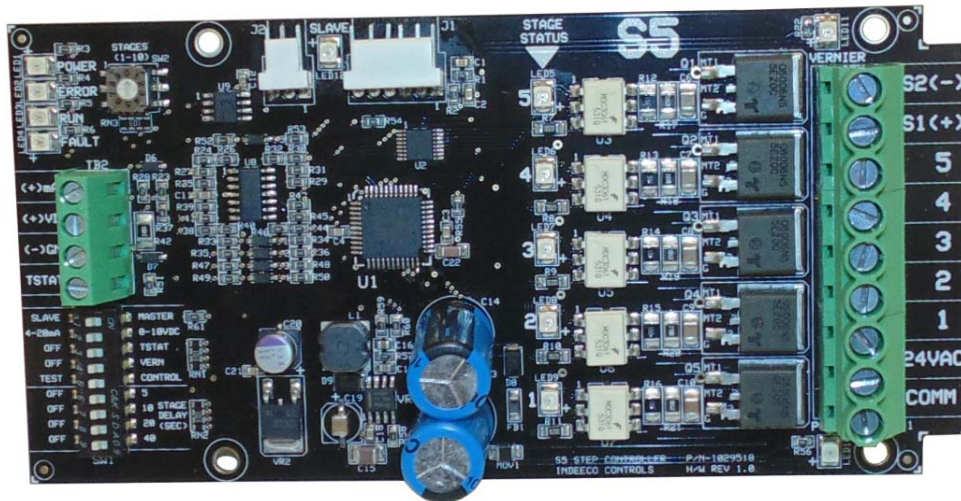

Owner's Manual

S5 SERIES

ELECTRONIC STEP CONTROLLER: LINEAR CONTROL WITH 10VDC PULSED VERNIER OUTPUT



This manual covers installation, setup, operation and troubleshooting. Read carefully before attempting to install, operate or service the S5 Series Step Controller.

IMPORTANT INSTRUCTIONS

SAVE THESE INSTRUCTIONS FOR FUTURE REFERENCE



425 Hanley Industrial Court • St. Louis, MO 63144
314-644-4300 • 800-243-8162 • FAX: 314-644-5332
www.indeeco.com • sales@indeeco.com

GENERAL DESCRIPTION / SPECIFICATIONS

GENERAL DESCRIPTION:

The S5 Series step controller is a microcomputer-based stage controller designed to provide low cost precise control for multi-stage applications. Common applications are HVAC duct heaters, industrial process air heaters and circulation heaters.

- Low voltage 24 VAC microcomputer-based stage controller
- Capable of controlling 24 VAC loads
- 5 stage controller with a pulsed 10 VDC vernier stage rated at 100 mA.
- Up to 10 stages of control when using a slave unit

STAGE SEQUENCING:

The S5 Series step controller operates in a linear control mode. The first stage ON will be the last stage OFF (LIFO).

For example: 1,2,3,4,5 ON then 5,4,3,2,1 OFF.

VERNIER OPERATION:

The S5 Series step controller supports a 10 VDC pulsed vernier stage to operate a slave SCR/SSR controller. This will result in more precise control than is otherwise possible with a standard on-off step controller. The slave SCR/SSR power controller provides proportional control (0-100% load) between the switching of the step controller stages.:

Sequence Control without Vernier:

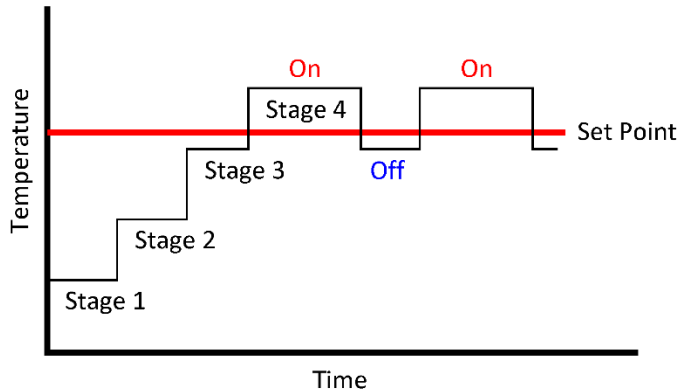

Sequence Control with Vernier:

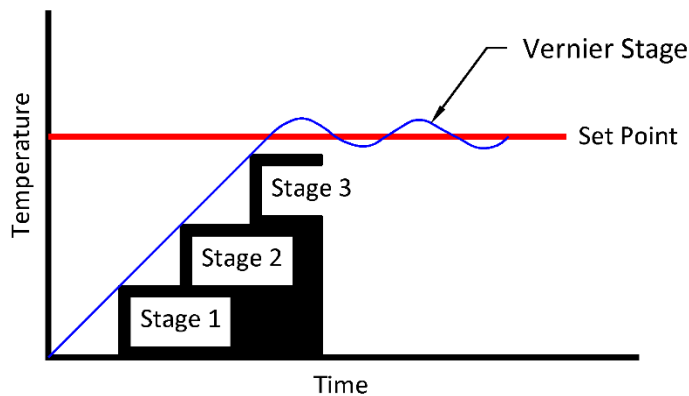

GENERAL DESCRIPTION / SPECIFICATIONS

FEATURES AND BENEFITS:

Micro-computer based control	Accuracy and reliability
Supports multiple input signals	Field adjustable dip switches to support both 0-10 VDC or 4-20 mA signals
Adjustable inter-stage delays	Field adjustable dip switches to support inter-stage delays of 1-75 seconds
Fail Safe	Unit cycles down to full OFF if input leads are open or shorted
Diagnostic capabilities	5 LED status lights provide detailed status information for troubleshooting.
Functional Test mode	Built-in test mode to verify load wiring, contactors and stage operation.

SPECIFICATIONS:

UL Recognized: File E52105, Guide XAPX2/8

Operating & Storage: -22°F to 185°F (-30°C to 85°C)

Relay Outputs: 24 VAC ±10%, 24VA max
Relay Wire Range: 10-24 AWG

Power Supply: 24 VAC ±10% ; 50/60 Hz ;
6.7 VA max – Base 5 stage operation with Vernier output.
Power Supply Wire Range: 10-24 AWG

Input Signal: Impedance: 10KΩ for VDC inputs ; 250Ω for mA inputs
Input Signal Wire Range: 14-30 AWG

Vernier Output: 10 VDC pulsed, 100 mA max. ; Wire Range 14-30 AWG

HOW TO ORDER

Typical Model Designation:

201 - S5 - M5
I II III

Model Number Description:

I - Product Code:
201 - Open board with a mounting plate
202 - Open board w/ standoffs

II - Basic Model: S5

III - Control Stages: M5

Slave Cable: 1030123

Cable is 36" long to make the master to slave connection. Contact factory if different length cable is desired.

SETUP INSTRUCTIONS

OPERATIONAL SETTINGS:

SLAVE	<input type="checkbox"/>	MASTER	
4-20 mA	<input type="checkbox"/>	0-10VDC	
OFF	<input type="checkbox"/>	TSTAT	
OFF	<input type="checkbox"/>	VERN	
TEST	<input type="checkbox"/>	CONTROL	
OFF	<input type="checkbox"/>	5	STAGE DELAY
OFF	<input type="checkbox"/>	10	(SEC)
OFF	<input type="checkbox"/>	20	
SW1 OFF	<input type="checkbox"/>	40	



CAUTION:

- Disconnect all power before changing any controller settings.
- For a master/slave application:
 - Connect the Vernier output to the master step controller.
 - All settings except switch 1 (ie. Master / Slave) on the slave controller are disabled and control is determined by the settings on the master.
 - Wire the control signal to the master unit only.

Switch	OFF	ON	Description
1	Slave	Master	Set control to operate as a slave or a master. All switches must be in the 'OFF' position for slave operation.
2	4-20 mA	0-10 VDC	Set control for operation with a 4-20 mA or a 0-10 VDC input signal.
3	Off	TSTAT	Set switch to 'TSTAT' when using a 3-wire thermostat with a 0-10VDC input signal.
4	OFF	VERN	Set to 'VERN' when utilizing the vernier control functionality of terminals S1(+) & S2(-).
5	TEST	CONTROL	Set control functionality to test mode or control mode. See section titled 'FUNCTIONAL TEST DESCRIPTION' for description of test sequence.

DELAY SETTINGS (Seconds):

Seconds	Switches 6 - 9			
	5	10	20	40
1	Off	Off	Off	Off
5	On	Off	Off	Off
10	Off	On	Off	Off
15	On	On	Off	Off
20	Off	Off	On	Off
25	On	Off	On	Off
30	Off	On	On	Off
35	On	Off	On	Off
40	Off	Off	Off	On
45	On	Off	Off	On
50	Off	On	Off	On
55	On	On	Off	On
60	Off	Off	On	On
65	On	Off	On	On
70	Off	On	On	On
75	On	On	On	On

INPUT SIGNAL TOLERANCES:

Nominal	Low Range Limit	High Range Limit
4-20 mA	3	21.0
0-10 VDC	0	10.5
TStat VDC	0	10.5

- Input signals above or below the Range Limits will result in an error indication. The controller will continue to operate, but an error light will indicate the out of range condition.
- See the section 'TROUBLESHOOTING' for error indication light definitions.
- Tolerance of +10% / -5% on range limit indications.

STAGE CONFIGURATION:

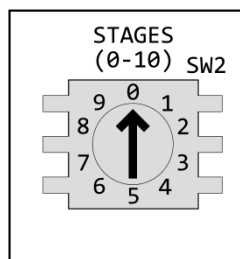

The STAGE dial is used to configure the proper number of stages.

- Set the stages to a value between 1 and 10 on the master controller.
- When a slave controller is used, always set the stages on the master controller to a value greater than 5.

WIRING & INSTALLATION INSTRUCTIONS

24 VAC POWER & RELAY OUTPUT WIRING:

When ordered, a 36" cord is supplied to make the master to slave connection. Contact factory if different length cable is desired. Use a properly fused Class 1 or Class 2 CSA or UL Recognized transformer to supply 24 VAC board power.

Master Controller with 24 VAC Relay Coils:

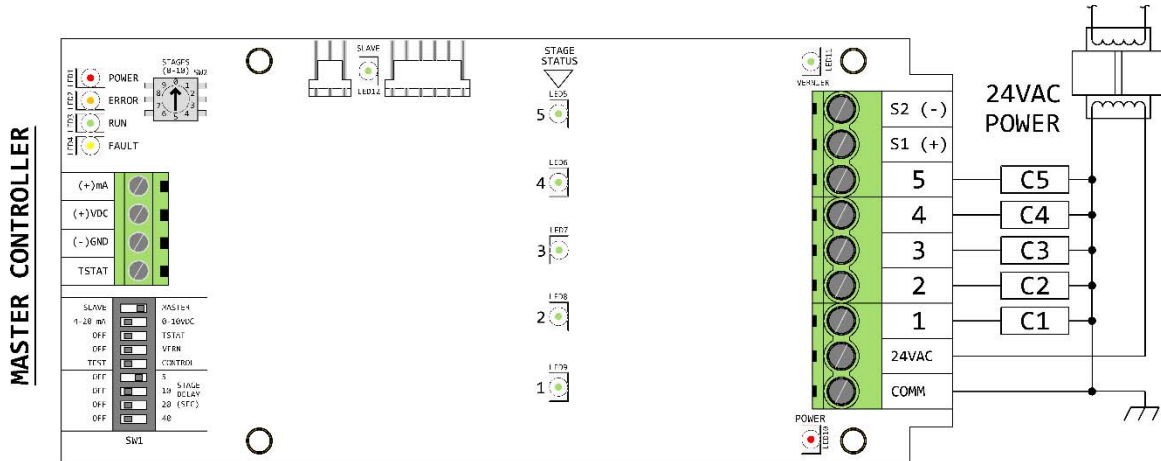

Master & Slave Controller with 24 VAC Relay Coils:

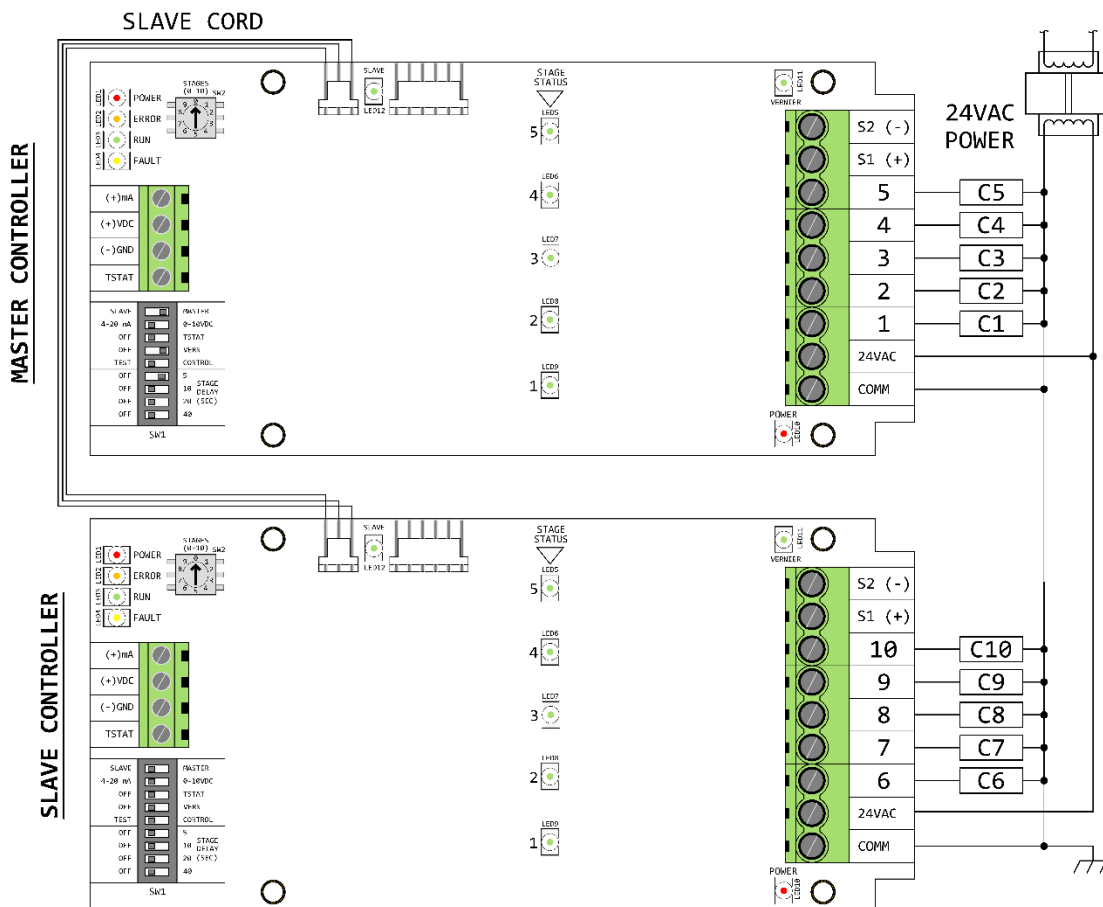

WIRING & INSTALLATION INSTRUCTIONS - CONTINUED

VERNIER STAGE WIRING:

- Rating: 10VDC pulsed, 100 mA max ; Wire Range: 14-30 AWG.
- The green Vernier light (LED11) on the master unit will cycle at a rate proportional to the Vernier output.
- A single slave SCR is shown. Multiple slaves can be wired together in parallel or series up a max output of 100 mA.

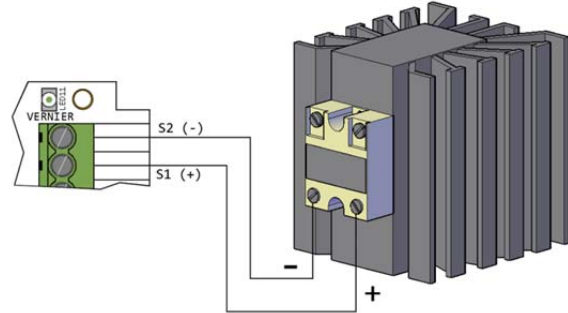

INPUT SIGNAL CONTROL WIRING:



CAUTION:

- Disconnect all power before changing any controller settings.
- Not maintaining the polarity of connections for the 0-10 VDC stand-alone thermostat could damage the remote thermostat. The 0-10 VDC output wiring terminal is referenced to common for proper operation of the thermostat.

- Input Signal Wire Range: 14-30 AWG.
- Impedance: 250Ω (mA), 10KΩ (VDC)
- The input signal control wiring is considered low-voltage, low energy and may be wired with Class 2 wiring where wet contact is not likely. Proper separation of circuits shall be maintained in the end-use equipment.

4-20 mA Signal
(D.D.C. Building Automation System)

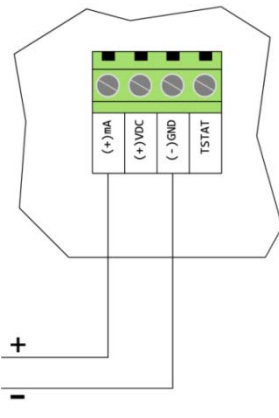

VDC Signal (2-Wire)
(D.D.C. Building Automation System)

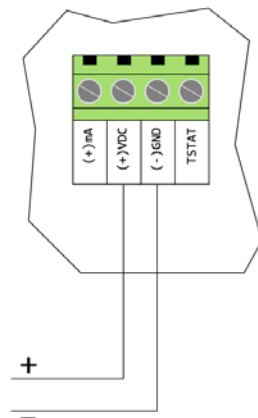

VDC Signal (3-Wire)
(24 VAC power required)

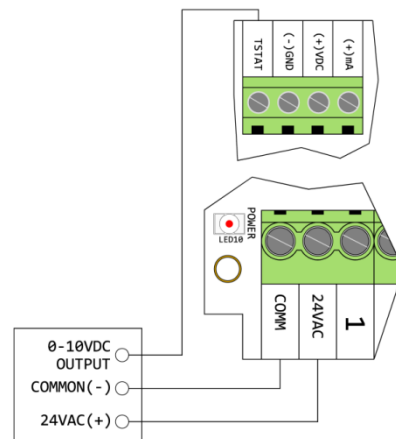

Units may be mounted in any position on a wall or inside a panel. Maximum mounting distance between a master & slave is 10 feet.

DIMENSIONS & INSTALLATION

Product Code 201 – supplied with mounting bracket.

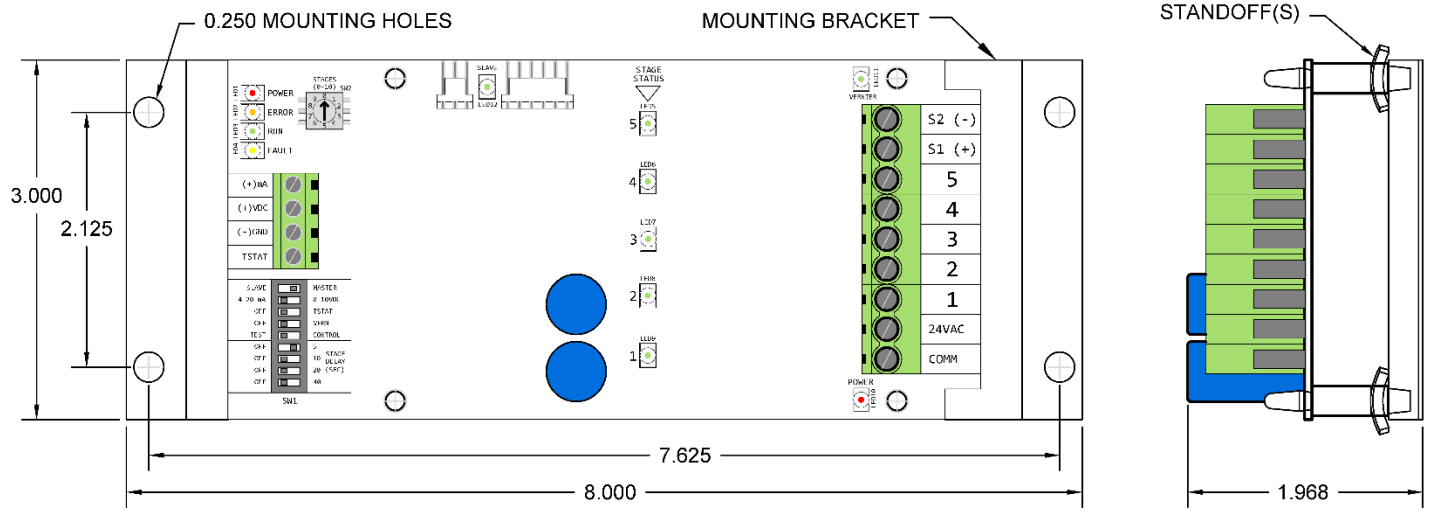

Product Code 202 - supplied with nylon standoffs that mate to 0.187 in. diameter mounting holes.

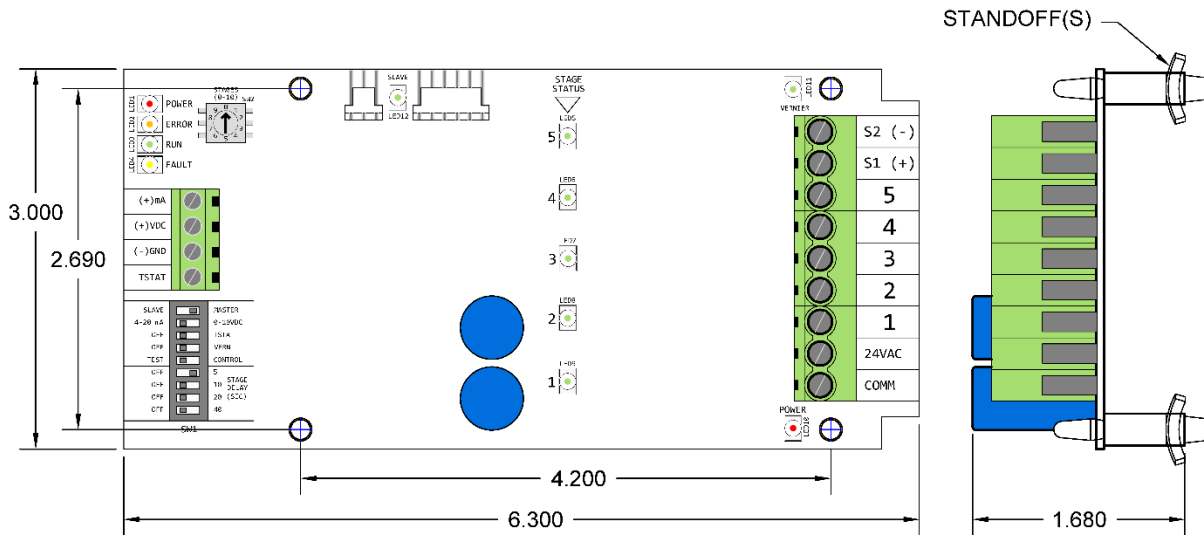

TROUBLESHOOTING

FUNCTIONAL TEST DESCRIPTION:



CAUTION:

- Disconnect all power before changing any controller settings.

The functional test mode can be used to verify board operation, stage settings and input signal. This mode will bypass both the inter-stage delay settings and input signal in order to sequence the stages according to the current status of the STAGE settings. The test sequence will also validate the input signal.

The board is configured for the functional test mode by setting switch 5 to 'TEST'. When the board is powered on in the functional test mode, the following sequence of events will take place:

1. The following LEDs will illuminate on power up and remain on during the cycling up and down of the stages:

LED			Master Unit	Slave Unit
Description	Number	Color		
Power	LED 1	Red	On	On
Error	LED 2	Yellow	On	Off
Run	LED 3	Green	On	On
Fault	LED 4	Yellow	On	Off
DC Power	LED 10	Red	On	On
Vernier	LED 11	Green	On	Off
Slave	LED 12	Green	On	On

2. The stage LED lights will cycle on and then off in a linear fashion (first on, last off) according the number of stages currently set. Both the inter-stage delay settings and input signal are bypassed during this test.
3. After the stage cycling is complete, the controller will perform a test to verify the input signal. All lights except the DC Power (LED 10) will turn off and one of the following lights will blink to conclude the functional test:

LED			Description of input test result if LED is illuminated
Description	Number	Color	
Power	LED 1	Red	Reversed polarity (mA or VDC)
Error	LED 2	Yellow	No input signal detected or signal detected is out of range *
Run	LED 3	Green	No issues. Valid input signal detected.

* Tolerance of +10% / -5% on range limit indications.

4. After test is complete, power down controller and set switch 5 back to 'Control'. The controller is ready to put into service. If the light sequence shown is not as expected based on the current setup parameters, please verify settings and contact factory for assistance.

TROUBLESHOOTING - CONTINUED

STATUS LIGHT LOCATIONS:

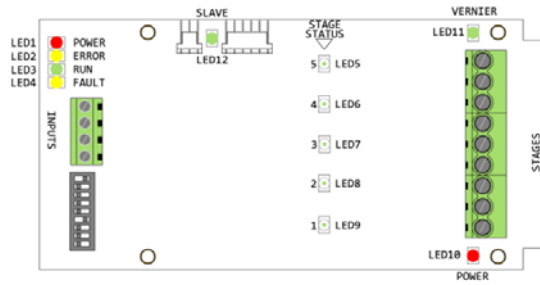

OVERALL MASTER BOARD STATUS:

Case	DC Power	Power	Error	Run	Fault	Description	Resolution
	LED10	LED1	LED2	LED3	LED4		
1						No 24 Vac power source or 35 VDC power supply failure.	Check 24 VAC power source.
2						24 or 12 or 5 VDC power supply malfunction.	Contact Factory.
3			2			Board error on startup.	See section 'DETAILED STATUS INDICATORS' for more information.
4						Controller at setpoint and monitoring input signal.	Normal Operation.
5				1		Controller responding to a change in setpoint.	Normal Operation.
6			3			Board error during operation.	See section 'DETAILED STATUS INDICATORS' for more information.
7			2	2		Slave board communication error at startup.	Verify master to slave connection, verify dip switch settings and cycle power.
8			3	2		Slave board communication error during operation.	Verify master to slave connection and cycle power.
9						Microprocessor error.	Cycle Power.

DETAIL STATUS INDICATORS:

Case	Fault	Description	Resolution
	LED 4		
1		Error light (LED 2) indicator without a corresponding Fault light indicates conflicting dip switch settings	Verify dip switch settings. In particular, verify TSTAT is ON only if 0-10 VDC is selected.
2	1	. Master stages set less than or equal to 5. Slave controller detected. Continued Operation.	Correct Master STAGE configuration selection
3	2	Without Error Light (LED2). Input signal out of range. Board will still function full ON or full OFF. Continued Operation.	Verify wiring, connections and signal source.
4	3	Master stages set greater than 5. Slave controller does not respond. Shut Down.	Verify Slave connection and dip switch settings.
5	Continuous	(*) Polarity reversed for selected input. Shut Down.	Verify wiring.

(*) Input polarity reversal:

- If detected during controller startup, the S5 prevents operation until the input polarity is corrected.
- If detected during controller operation, the S5 will allow operation for 10 seconds with run light (LED3) blinking before shutdown. If the polarity is corrected before the 10 second time-out, the error is cleared and normal operation will resume.

Notes:

1. Numbers in colored boxes in the table above indicates the number of light blinks.
2. The green Vernier light (LED11) on the master will cycle at a rate proportional to the Vernier output.
3. The green Run light (LED3) indicates that the controller is operational.
4. The green Run light (LED3) should blink 1 time on startup. Multiple blinks indicate an incorrect software version loaded.