

Brasch Manufacturing Company

INSTALLATION INSTRUCTIONS ARCHITECTURAL DRAFT BARRIER SERIES DBCF & DBCT AND WITH OPTIONAL PEDESTALS

GENERAL:

BRASCH ARCHITECTURAL DRAFT BARRIER HEATERS MAY BE MOUNTED INDIVIDUALLY, END TO END AND WALL TO WALL. EACH HEATER IS FACTORY PRE-WIRED, READY FOR BRANCH CIRCUIT CONNECTION. DBCT & DBCF HEATERS ARE CONSTRUCTED OF .100 INCH EXTRUDED ALUMINUM FRONT COVERS AND 16 GAUGE STEEL BACKS. DBCT PEDESTAL HEATERS AND DBCF HEATERS WITH OPTIONAL FINISHED BACKS HAVE A .100 INCH EXTRUDED ALUMINUM BACK AS WELL AS AN EXTRUDED ALUMINUM FRONT.

RECEIVING:

1. MAKE SURE THAT THE NUMBER OF CARTONS AGREE WITH THE BILL OF LADING, PACKING LIST AND ORIGINAL ORDER.
2. MATERIAL WAS SHIPPED IN GOOD ORDER AND AMERICAN STABILIS INC. HOLDS CLEAR BILL OF LADING, THEREFORE ANY CONCEALED DAMAGE MUST BE REPORTED AT ONCE TO THE CARRIER FOR INSPECTION AND SETTLEMENT.
3. ALL MATERIAL IS SHIPPED FOB FACTORY AND THEREFORE IT IS IMPORTANT TO NOTE ALL SHIPPING DAMAGE. AMERICAN STABILIS MAY ASSIST THE CUSTOMER TO FILE A CLAIM, BUT IT IS THE CUSTOMER'S RESPONSIBILITY TO FILE THE CLAIM WITH THE CARRIER.

ROUGH-IN WIRING:

1. RUN BRANCH CIRCUIT OF PROPER VOLTAGE AND WIRE SIZE TO LOCATION OF THE TERMINAL BOX OF THE HEATER. TABLE BELOW PROVIDES CORRECT WIRE SIZE FOR WIRE ENTRY.

TABLE 1.

	ROUGH IN	MAXIMUM WATTS PER CIRCUIT USING 75°C WIRE			
	WIRE SIZE	120V	208V	240V	277V
COPPER WIRE	14	1440	2496	2880	3324
	12	1920	3328	3840	4432
	10	2880	4992	5760	6648
ALUMINUM WIRE	12	1440	2496	2880	3324
	10	2400	4160	4800	5540

2. WIRE ENTRY INTO A DRAFT BARRIER INSTALLATION IS COMMONLY MADE INTO ONE DRAFT BARRIER HEATER. THROUGH WIRING (FACTORY FURNISHED) IS USED FOR CONNECTION TO ADJACENT HEATERS.

3. $\frac{1}{2}$ & $\frac{3}{4}$ KNOCKOUTS ARE LOCATED AT EACH END OF THE HEATER BACK PANEL FOR WIRE ENTRY. A KNOCKOUT IS ALSO LOCATED ON EACH SIDE OF THE JUNCTION BOX.

4. ALL WIRING AND ELECTRICAL GROUNDING OF THE HEATER BACK PANEL TO BE IN ACCORDANCE WITH NATIONAL ELECTRICAL CODE AND APPLICABLE LOCAL CODES. A GROUNDING TERMINAL IN THE HEATER SPLICE COMPARTMENT IS PROVIDED FOR THIS PURPOSE.

TO INSTALL DBCF, DBCT HEATERS:

1. ONCE INSTALLATION HEIGHT HAS BEEN DETERMINED, PROPER MARKINGS ALONG THE WALL SHOULD BE MADE TO INSURE THAT THE HEATER WILL MOUNTED EVENLY. IF THE WALL SURFACE IS NOT EVEN, ATTACH THE BACK PANEL TO THE HIGH SPOTS. THIS WILL ELIMINATE A DISTORTED APPEARANCE. SHIMS CAN BE USED TO MAINTAIN A STRAIGHT LINE ALONG THE FRONT SURFACE IF NECESSARY. SERIES DBCT AND DBCF HEATERS MUST BE MOUNTED A MINIMUM OF 3" FROM FINISHED FLOOR.

2. WHEN MULTIPLE HEATERS ARE TO BE WIRED TOGETHER, REMOVE TERMINAL BOX END KNOCKOUTS.

3. MOUNT THE BACK PANEL TO THE WALL USING SUITABLE FASTENERS (BY INSTALLER).

4. WHEN HEATER SECTIONS ARE MOUNTED END TO END, INSTALL A CHASE NIPPLE AND LOCKNUT IN THE TERMINAL BOX END KNOCKOUTS TO INSURE GROUNDING CONTINUITY AND TO PROTECT THE WIRING. WHERE HEATER SECTIONS ARE SPACED APART, RIGID CONDUIT (BY INSTALLER) SHOULD BE USED TO ENCLOSE THE WIRE AND INSURE GROUNDING CONTINUITY. USE RIGID CONDUIT (BY INSTALLER) WHEN WIRING THROUGH CORNER SECTIONS TO ENCLOSE WIRE AND INSURE GROUNDING CONTINUITY.

NOTICE:

"TO REDUCE THE RISK OF FIRE, DO NOT USE GASOLINE OR OTHER FLAMMABLE VAPORS AND LIQUIDS IN THE VICINITY OF THE HEATER"

NOTICE:
 TO ENSURE A PROPER INSTALLATION, MAKE SURE THAT ALL PIECES ARE SECURELY SNAP FITTED. FOR EASE OF INSTALLATION, SNAP BOTTOM OF FRONT COVER FIRST, AND THEN SNAP TOP PART OF THE FRONT COVER TO THE BACK PLATE. DO NOT OPERATE HEATER UNLESS FRONT COVER IS IN PLACE.

CAUTION: HIGH TEMPERATURES
 KEEP ELECTRICAL CORDS AWAY FROM HEATER. DO NOT PLACE HEATER BELOW ELECTRICAL CONVENIENCE RECEPTACLE. DO NOT INSTALL HEATERS AGAINST VINYL COVERED SURFACES OR FOAM SURFACES. DO NOT INSTALL HEATERS ON PAPER OR FABRIC COVERED SURFACES. KEEP ALL DRAPERIES & FURNITURE A MINIMUM OF 4" IN FRONT OF HEATER AND 12" ABOVE HEATER.

WARNING: HIGH HEAT MAY DISCOLOR SYNTHETIC FABRICS OVER TIME.

NOTICE:
 WHEN USING EITHER 1/2" OR 3/4" EMT FOR FIELD WIRING, DO NOT EXCEED ALLOWABLE NUMBERS OF CONDUCTORS ACCORDING TO THE NATIONAL ELECTRIC CODE.

CONTROLS:
 DESCRIPTION: SINGLE POLE
 CATALOG NO.: DBCF/DBCT-ITS
 RATED 25 AMPS AT 120-277. 50-90°F
 TEMPERATURE RANGE. TAMPERPROOF
 AND ADJUSTABLE THRU DISCHARGE
 LOUVER.

DESCRIPTION: DISCONNECT SWITCH
 CATALOG NO.: DBCF/DBCT-IDS
 DOUBLE POLE RATED 20 AMPS AT
 120-277V.

WHEN HEATERS ARE FURNISHED WITH
 CONTROLS, MAKE CERTAIN THAT THE
 HEATER OR HEATERS DO NOT EXCEED
 THE LOWEST AMPERAGE RATING OF
 THE CONTROLS FURNISHED. FOR
 EXAMPLE, IF A THERMOSTAT AND
 DISCONNECT ARE FURNISHED, THE
 THERMOSTAT IS RATED AT 25 AMPS
 AT 240 AND 277. THE DISCONNECT IS
 RATED 20 AMPS, 240 AND 277. THE
 COMBINATION OF HEATERS SHOULD
 NOT EXCEED 20 AMPS AT 240 OR 277.

DESCRIPTION: DOUBLE POLE THERMOSTAT
 CATALOG NO.: DBCF/DBCT-ITD
 RATED 25 AMPS AT 120-277. 50-90°F
 TEMPERATURE RANGE. TAMPERPROOF
 AND ADJUSTABLE THRU DISCHARGE
 LOUVER.

- FIELD WIRING WITH INTEGRAL CONTROLS
- INTEGRAL THERMOSTATS: WIRE ENTRY FROM EITHER END.
 - DISCONNECT SWITCH: RIGHT HAND ENTRY.
 - THERMOSTAT AND DISCONNECT: RIGHT HAND ENTRY.
 - RELAYS: RIGHT HAND ENTRY-CONTROL SECTION
 - THERMOSTAT, DISCONNECT AND RELAY: RIGHT HAND ENTRY-CONTROL SECTION.

WIRING DIAGRAMS

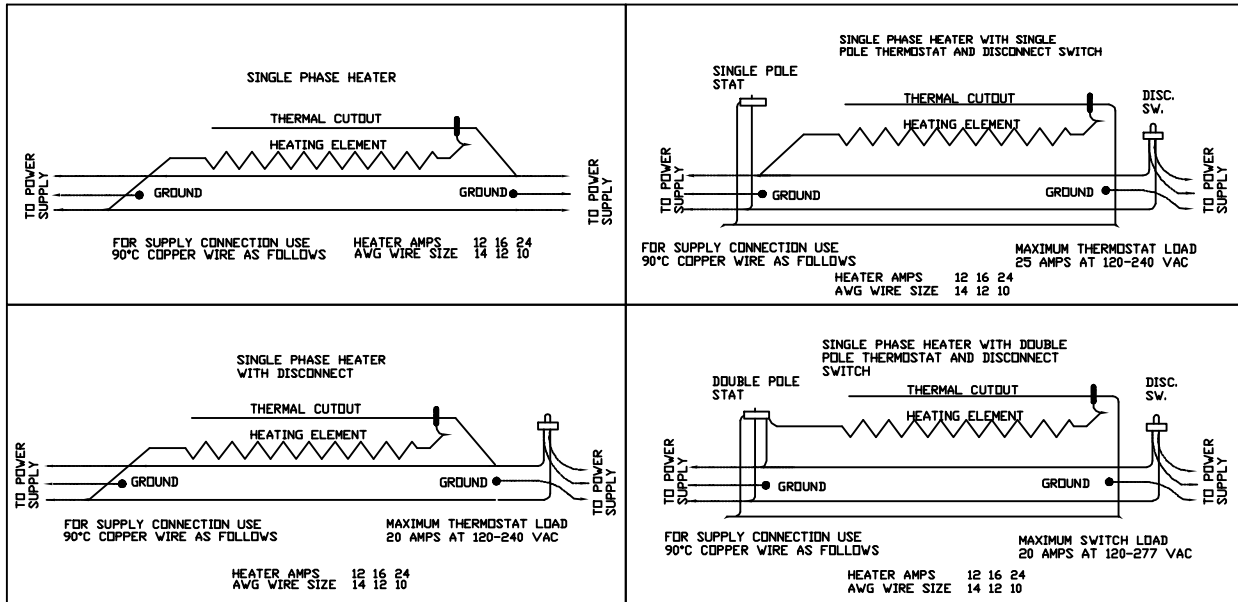

WIRING DIAGRAMS-CONTROL SECTION

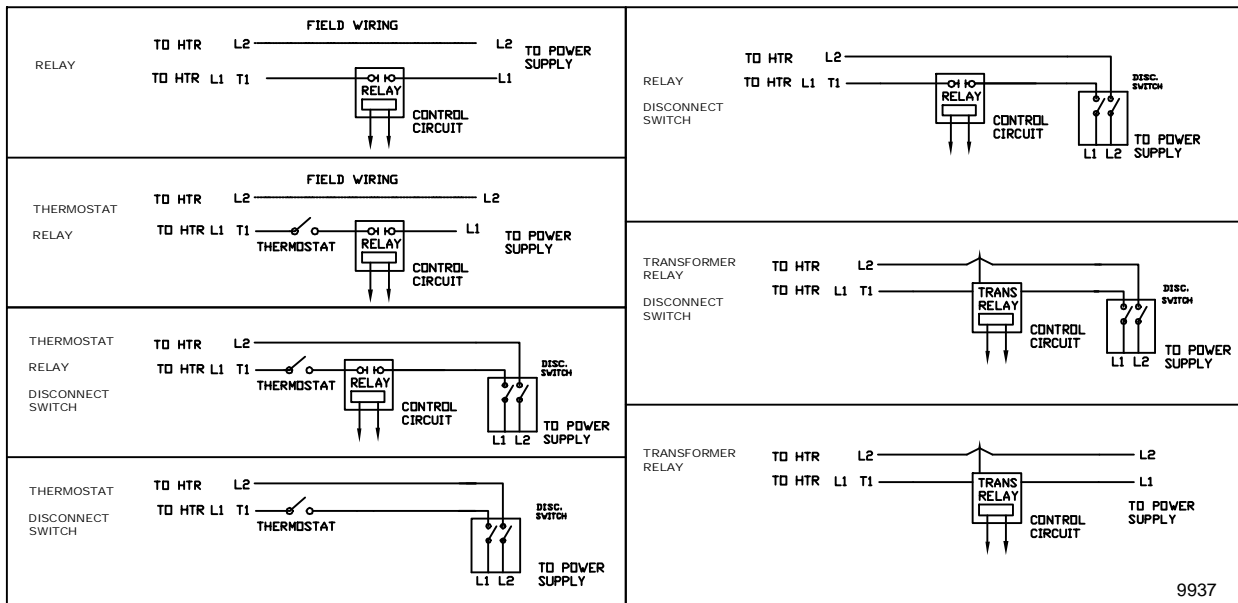

INSTALLATION

KNOCKOUTS AND MOUNTING HOLES TYPES DBCF AND DBCT

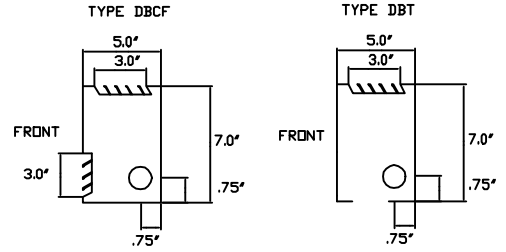
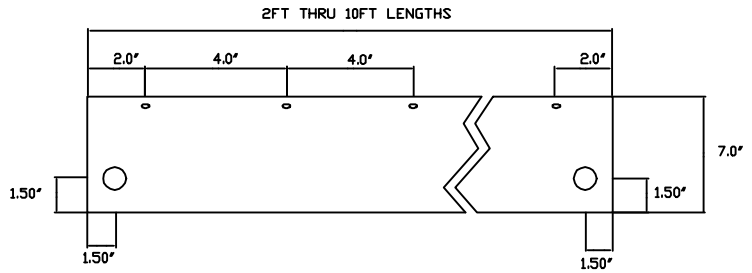
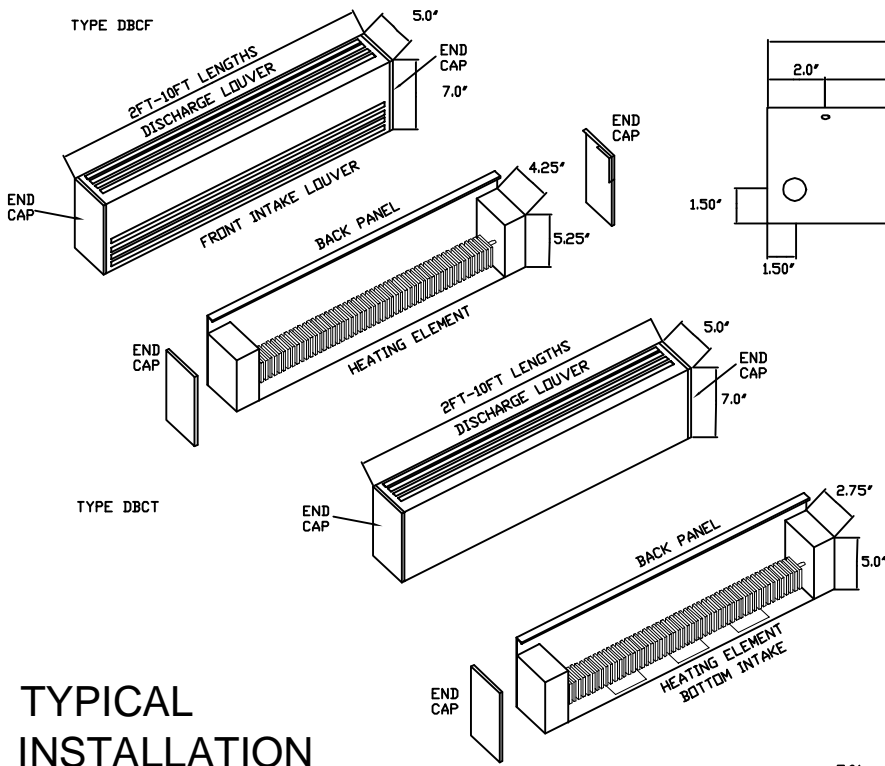

TYPICAL INSTALLATION

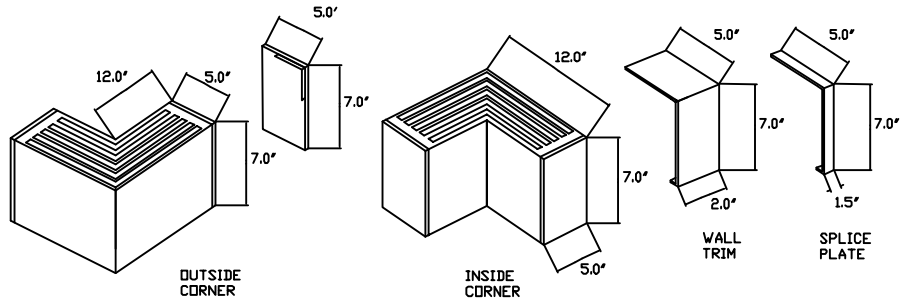
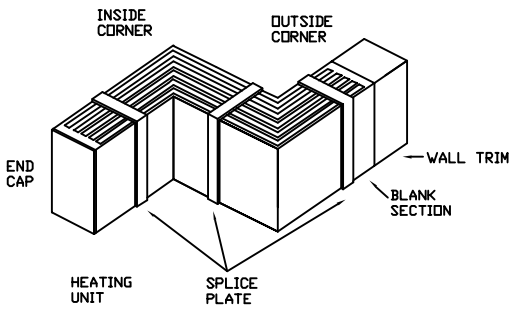

ACCESSORIES

ARCHITECTURAL PEDESTAL HEATERS
SERIES DBCF-DBCT PD
DBCF 100-650, DBCT 100-750 WATTS PER FOOT

