

BRASCH MANUFACTURING COMPANY, Inc.

GAS DETECTOR / VENTILATION CONTROLLER

Installation / Operation Manual

**Brasch Gas Detector with
Digital Display, Ventilation Control
Relays and Internal Alarm**

If you have questions concerning the installation or operation of this detector not answered by the manual, please call our Customer Service Department at 1-660-327-4550. FAX: 1-660-327-4560

Please have the following information available:

Model number (located on the front label)
Serial number (located on the front label)
Date of manufacture (on front label)
Name of distributor where purchased

Brasch Manufacturing Company, Inc.
2310 Millpark Drive
Maryland Heights, Missouri 63043
(866) 882-1677, Fax (314) 291-0646

May, 2008
JUL, 2006
DEC, 2003
JAN, 2003
IOM 1-687

Table of Contents

Operation Safety Notice _____	iii
Quick Installation Guide _____	iv
Part One – Installation and Operation	
● Description _____	1
● Mounting the Detector _____	1
● Connecting the Power Supply _____	2
● Controlling the Ventilation System _____	3
● Connecting the External Alarm _____	4
● Connecting the Voltage or Current Proportional Output _____	4
● Applying Power For the First Time _____	4
● Using the Self-test Feature _____	5
Part Two – Technical Specifications	
● Product Specifications _____	6
● Target Gas Specifications _____	7
● Description of Front Panel Indicators _____	7
● How the Detector Senses the Target Gas _____	8
● Obtaining the Best operation _____	9
● Typical System Wiring _____	10
Part Three – Troubleshooting and Maintenance	
● Testing the Response to the Target Gas _____	11
● Checking and Replacing Fuses _____	12
● Replacing the Sensor _____	12
● Suggested Repair Parts _____	13
Part Four – Common Installation/Operation Mistakes	
● Ventilation Components Wired to the Wrong Relays _____	14
● Configuration Jumpers In Wrong Positions _____	14
● Low Alert Level Set At Wrong Concentration _____	14
● Delay Period Not Set Correctly _____	14
● Detector Mounted In An Unsatisfactory Location _____	14
Part Five – Limited Warranty	
● Warranty Statement _____	16
● Service and Repair Procedures _____	16
Part Six – Appendix	
● Model Numbers and Descriptions _____	17
● Detector Assembly Views _____	19
● Using the Proportional outputs _____	21

Operation Safety Notice

Certain procedures and operations detailed in this manual require that specific precautions be taken prior to beginning the procedure or operation. When precautions are required, a notice will be printed in an appropriate location in the manual. The user is urged to read and understand all such notices.

Types of Notices

Three types of notices may be used in this manual to describe the severity of the situation encountered.

WARNING This notice indicates that conditions exist that could cause personal injury or loss of life.

Caution Conditions exist that could cause damage to the equipment or other property.

Note Special consideration should be given to the procedure or operation or an unexpected operational result could occur.

Quick Installation Guide

Please read this entire manual before attempting to install and operate this gas detector. But, if you do not read the manual, this Quick Installation Guide will provide the basic steps necessary to install and operate the detector. In each step, reference is made to the portion of the manual where more complete information can be obtained.

Follow the basic steps listed below to install and operate your Brasch Gas Detector. However, we recommend that you read the complete manual to obtain a more detailed description of the detector's capabilities.

Installing and operating your Brasch detector:

Step 1

Determine the location for mounting your detector(s). The location(s) may be indicated on the architectural drawing. Also, the owner or designer of the facility may be consulted. Mounting guidelines can be found on **page 1** of this manual.

Step 2

WARNING

This detector may require the use of voltage levels high enough to cause fatal injuries. Proper procedures must be followed anytime work is performed on this unit.

Only Qualified Personnel Should Attempt To Install, Maintain Or Service This Equipment.

Provide a dedicated circuit, at the required operating voltage, at each detector mounting location. Follow all national and local wiring codes. The wiring should be at least 14 AWG. A conductor, connected to the earth ground, should also be provided. The circuit must include a disconnect switch located within easy reach of the detector.

If the detector operates from a voltage other than 120 VAC, be sure that the step-down transformer provides the correct secondary voltage and has the necessary volt-amp rating. The power requirement for the detector is listed in the upper, right hand corner of the front panel label.

CAUTION

Operating this detector with the incorrect voltage and power requirements can cause internal electrical components to overheat and fail. Operation with the wrong power requirement will void the manufacturer's warranty, and the installer will be responsible for any damage that occurs.

Contact Brasch Manufacturing Company before connecting power to the detector if you are unsure of the correct power requirement.

Color coded wires, exiting the detector housing through the top, left conduit connector, are provided for connecting the operating voltage to the detector. Therefore, it should not be necessary to remove

the front cover from the detector when connecting the voltage supply. Connect the **hot** power conductor to the **black** wire, connect the **neutral** conductor to the **white** wire and connect the **ground** conductor to the **green** wire.

Refer to **page 2** for further information.

Step 3

In most cases, wiring of the ventilation control relays can be completed without opening the front panel of the detector. Colored coded wires, connected to the internal relay terminals, extend outside the housing through the conduit connector located just to the right of the power leads. Use only the necessary wires required for control of the ventilation components. Cover or seal the ends of any unused wires and place them safely inside the conduit.

Determine the type and number of fans and/or make-up air units the detector will control. For proper installation, you must first determine how and when the fans/make-up air units will operate. Many installations have only one or two ventilation components designed to operate simultaneously. These components usually operate from the LA1(**red wire**) and LA2(**yellow wire**) terminals of the low alert relay. Other ventilation systems contain multiple components designed to operate in two stages. Connect the primary ventilation components to the LA1(**red wire**) and LA2(**yellow wire**) terminals of the low alert relay and connect the secondary components to the HA1(**blue**) and HA2(**brown**) terminals of the high alert relay.

Do not exceed the specified voltage and power limits of the relays, (**see page 6**). Most installations require motor starters or larger relays to provide the necessary power requirements for the ventilation components.

For more information concerning ventilation system operation, read **page 3** of this manual.

Step 4

Determine if the installation requires an external alarm. If so, provide the proper wiring and connect the wires to the required voltage source. Connect the wiring to the alarm relay at terminals AL1(**gray**) and AL2(**purple**) using the correct color coded wires.

Page 4 provides more information concerning the alarm feature.

Step 5

Once you are sure that the wiring connections are correct, apply power to the detector circuit. When power is first applied, only the green power indicator will glow and the decimal point in the display will be on. If the "ALM. OFF/TEST" switch is not actuated, this condition will continue for five minutes. At the end of this five minute period, the detector will enter the operation mode. If no detectable gas concentration is present, the display will indicate "0.0" and the appropriate "SENS A" or "SENS B" indicator will glow. If the detector contains two sensors, the "SENS A" and "SENS B" indicators will alternately glow approximately every four seconds.

Refer to **page 4** for more information concerning the initial startup.

STEP 6

This detector is equipped with a self-test feature that is active only during the first five minutes after power is applied. This feature will test the display for proper operation and also actuate the low alert, high alert and alarm relays. Any ventilation components connected to these relay terminals will operate if their power supply is active. The ventilation component relays will remain on for 30 seconds to allow sufficient time for testing if problems occur. However, the alarm relay and internal alarm buzzer will actuate for only three seconds. There is a 30 second period between each relay actuation. At the end of this test, the detector will enter the operation mode described in step 5.

To enter the self-test mode, press the "ALM. OFF/TEST" switch for approximately one second.

Page 4 contains a more complete discussion of this self-test feature.

The Brasch Gas Detector is now ready to monitor for the presence of the target gas and control the ventilation system to efficiently remove the gas from the protected area.

PART ONE – INSTALLATION and OPERATION

Description

The Brasch Gas Detector is designed to function as a “Stand Alone” gas sensor and ventilation controller. The detector consists of a sensor, control relays and digital control circuitry. A microprocessor monitors the signal from the sensor circuitry, compares that signal to preset values and controls three relay contacts based upon that comparison. These relay contacts then provide the signals that control the ventilation components. A four digit display and status lamps are mounted on the front panel and provide a visual indication of the detector’s operational condition.

The sensors used in the detector operate on the **electrochemical** principle. Sensors are available to detect such target gases as **carbon monoxide, nitrogen dioxide and oxygen**. A current is produced when the target gas reacts chemically with water inside the sensor. This small current is changed to a voltage by the detector’s circuitry, amplified and changed to a digital signal by the microprocessor. This digital signal is proportional to the gas concentration present at the sensor. After comparing the digital signal to preset values, the microprocessor produces signals that actuate the appropriate relays and lamps. Also, the current gas concentration is indicated on the front panel, liquid crystal display. The actual gas concentration is sampled and updated approximately every four seconds.

The detector’s circuitry consists of two printed circuit boards mounted inside a polycarbonate housing. The housing has a NEMA 1 rating and is supplied with conduit fittings so that the detector can mount directly to a standard four inch conduit box. Short lengths of 16 AWG wires, connected to the power and relay terminals inside the housing, extend through the conduit fittings. These wires are color coded, and most installations do not require opening the detector housing.

Space is available inside the detector housing for mounting two sensor assemblies. The additional sensor assembly allows the detection of a second target gas. Also, a remote sensor can be attached by means of a six conductor, shielded cable. Please call your Brasch Manufacturing distributor, or the Brasch factory, to obtain information on the currently available types of sensors.

Mounting the Detector

The ability of the detector to sense the target gas and efficiently control the ventilation system depends greatly upon proper selection of the mounting location. This detector monitors the area around it by sampling the air that passes by the sensor. Since the sensor is mounted inside the housing, air must diffuse through the bottom housing vents and pass by the sensor on its way out the top housing vents. Therefore, the detector should be positioned where it can sample air that contains a target gas concentration representative of the average value in that area.

When determining the mounting location, give special consideration to the following guidelines.

- Use one detector for each 7000 to 9000 square feet of area to be monitored.
- The types of gases the detector is designed to monitor have densities approximately equal to that of air. For maximum safety, mount the detector at the average breathing height.
- Avoid mounting locations that would not be representative of the average gas value in that area. Locations near doorways, fans, ventilation inlets and outlets and areas with high volume of air flow should be avoided.

- Avoid locations that would allow direct contact with water. Mounting the detector near outside garage doors may allow rain to hit the detector when the door is open.
- Avoid locations that are directly in the outlet air vents of heaters or air conditioners.
- Do not allow exhaust from engines to flow directly on the detector. This detector is designed to sense gas concentrations that are 300 to 1000 times less concentrated than the gas levels found in engine exhaust. Also, engine exhaust contains high levels of other components. These components can shorten the useful life of the sensor if they contact the sensor before being diluted by the room air volume.
- Avoid mounting locations where the detector may be hit by passing vehicles. If the detector must be mounted in these locations, provide a shielding cage around the detector for protection.
- Do not restrict the air flow to the top or bottom of the detector housing.
- Do not mount the detector near containers of chemicals such as gasoline, kerosene, alcohol or other cleaning fluids. High level concentrations of these chemicals may be mistaken as the target gas by the sensor and cause false readings. Also, some welding gases may cause false readings.

The detector is attached in the mounting position in one of two ways.

- Attach the housing to a four inch conduit box using the conduit fittings supplied with the detector. If you use this method, make sure that the four inch box is securely attached with screws to a solid support base. Firmly tighten the threaded nuts on the conduit fittings inside the four inch box so they will not loosen over time.
- Attach the housing to a solid support base using screws through the internal housing mounting holes. This method requires removal of the housing cover to gain access to the mounting holes. A mounting hole is located at the top and bottom of each of the housing end walls.

Find a flat area at least 8" high by 11" long and place the back of the open housing flat against it. Using a pencil, or other slender marking tool, mark the location of the four mounting holes using the housing as a template. Start the screws without the housing in place to avoid any possibility of damage to the housing or circuit board. Remove the screws, place the housing in position and install the mounting screws. Do not over-tighten the screws and crack the plastic housing. Be careful not to damage the printed circuit board. Carefully replace the housing cover after properly aligning the lamps and "ALM. OFF/TEST" switch in their cover holes. Securely tighten all six of the cover retaining screws.

Connecting the Power Supply

WARNING

This detector may require the use of voltage levels high enough to cause fatal injuries. Proper procedures must be followed anytime work is performed on this unit.

Only Qualified Personnel Should Attempt To Maintain Or Service This Equipment.

Brasch Gas Detectors are designed to operate from either 120 VAC or 24 VAC. Selection of the operating voltage is made by the user at the time the detector is ordered. The correct voltage is listed in the upper, right corner of the front panel label.

While this detector does not require much power to operate, it usually is located near machines that do consume large amounts of power. When these large machines operate, they cause large voltage spikes to appear on the AC wiring. These spikes can interfere with the proper operation of the detector. The easiest way to avoid much of this interference is by providing power to the detector through a dedicated circuit from the service panel. In some very noisy situations, a line filter can be connected in the power supply circuit just ahead of the wiring connections at the detector.

Note

Do not operate the detector on the same AC circuit with the ventilation components. Doing this will almost always cause improper detector operation.

Provide a dedicated circuit, at the required operating voltage, at each detector mounting location. Follow all national and local wiring codes. The wiring should be at least 14 AWG. A conductor, connected to the earth ground, should also be provided. The circuit must include a disconnect switch located within easy reach of the detector.

If the detector operates from a voltage other than 120 VAC, be sure that the step-down transformer provides the correct secondary voltage and has the necessary volt-amp rating. The power requirement for the detector is listed in the upper, right hand corner of the front panel label.

CAUTION

Operating this detector with the incorrect voltage and power requirement can cause internal electrical components to overheat and fail. Operation with the wrong power requirement will void the manufacturer's warranty, and the installer will be responsible for any damage that occurs.

Contact Brasch Manufacturing Company before connecting power to the detector if you are unsure of the correct power requirement.

Color coded wires, exiting the detector housing through the top, left conduit connector, are provided for connecting the operating voltage to the detector. Therefore, it should not be necessary to remove the front cover from the detector when connecting the voltage supply. Connect the **hot** power conductor to the **black** wire, connect the **neutral** conductor to the **white** wire and connect the **ground** conductor to the **green** wire.

Controlling the Ventilation System

As an energy saving device, the main function of the Brasch Gas Detector is to operate the ventilation system only when necessary. To accomplish this, the detector is equipped with two control relays. The contacts of these relays can control various ventilation system configurations. Figures 1, 2 and 3 on **page 10** gives examples of the wiring for the most common systems. Coil control signals on relays for damper and make-up air units can also be connected across the detector's relay contacts so that these components actuate simultaneously with the exhaust fans. However, do not exceed the maximum ratings of the relays, (**see page 6**).

Please give special attention to the note on each wiring diagram. Jumper TP3 must be in the proper configuration before power is applied or the ventilation system will not function correctly. The detector is shipped from the factory with TP3 in the 50/100 % position. Therefore, unless you use a two speed motor starter, or a low speed fan is to be off if a high speed fan is on, you can connect the ventilation wiring without removing the detector front panel cover.

TP3 is located near the bottom edge of the control board approximately 2 ½ inches from the right side. To change the setting to 2-speed, lift the shunt off TP3 and move it one pin to the left. Then slide it back on the pins.

Connecting the External Alarm

The Brasch Gas Detector comes standard with an internally mounted alarm. If the target gas concentration exceeds the “HIGH ALERT” level and remains there for more than 15 minutes, this alarm will sound. There are also a set of external alarm contacts that close at the same time. These external contacts, AL1(gray) and AL2(purple), can be used to trigger an alarm element mounted at a remote location. If these alarms sound, take immediate action to determine why the gas is not being removed from the area monitored by the detector. The possibility may exist that the ventilation fan has lost power, wiring to the fan has failed, the fan fuses have opened or a very large source of target gas is present. In any case, the area should be evacuated until the problem is solved and the gas concentration has returned to normal. Once the gas concentration drops below the “HIGH ALERT” level, both the external and internal alarms will reset to the normal condition.

The internal alarm can be turned off by pressing the “ALM. OFF/TEST” switch for approximately one second. The external alarm will remain activated. Once the gas concentration drops below the “HIGH ALERT” level, the external alarm will deactivate and the internal alarm circuit will reset. Both alarms will activate if another alarm condition occurs.

Figures 1, 2 and 3, on **page 10**, show typical alarm wiring.

Connecting the Voltage or Current Proportional Output

The Brasch GSE gas detectors include circuits that provide either a current loop or voltage proportional output for each gas sensor. Each output produces a linear response over the full scale range of the sensor. A detailed description of these outputs can be found starting on **page 21**.

Applying Power For the First Time

Once all the wiring connections are complete, the detector is ready for power to be applied. The first five minutes after the power is on is a warm-up period. Only the green power lamp will be glowing. The display will be blank except for the decimal point on the right hand side. At the end of this warm-up period, the detector will begin to display the target gas concentration and the appropriate sensor lamp will glow. In most cases, the gas concentration will be “0.0”. However, if the target gas is present in the monitored area, the display will indicate the actual concentration.

During this warm-up period, the self-test feature can be activated by pressing the “ALM. OFF/TEST” switch for approximately one second. The detector will then enter the test mode. The test mode lasts for five minutes. The warm-up period is extended by the amount of time that has expired since power on until the self-test is started.

Using the Self-Test Feature

The self-test feature on this detector provides a convenient way to test the major functions of the complete system. This feature is only active during the first five minutes after power is applied. Activate the self-test by pressing the “ALM. OFF/TEST” switch for one second.

The self-test performs the following:

- Tests each display digit by displaying “0” through “9”.
- Activates the “LOW ALERT” relay and indicator lamp for 30 seconds.
- Waits for 30 seconds.
- Activates the “HIGH ALERT” relay for 30 seconds.
- Waits 30 seconds.
- Activates the “ALARM” relay, indicator lamp and internal alarm for 3 seconds.
- Waits 30 seconds
- Begins to monitor and display the target gas concentration in the area.

Before using the self-test feature, we recommend testing the ventilation system wiring for correct connections and operating the ventilation components manually. Make any wiring changes and replace any defective components. Any problems found during the self-test can then be identified much easier.

Although the self-test feature tests much of the detector’s functions, it does not test the sensor’s response to the target gas. Part three, **page 11**, gives hints and procedures for testing the sensor’s response.

PART TWO – TECHNICAL SPECIFICATIONS

Product Specifications

Power: (specified by customer at time of order)	120 VAC Input Voltage 50/60 Hz. 0.125 Amps
	24 VAC Input Voltage 50/60 Hz. 0.500 Amps
Installation Category:	II (local level, over-voltage transients less than 500 volts)
Operating Temperature:	Storage -50° C to 120° C (-58° F to 248° F)
	Operating -15° C to 40° C (5° F to 104° F)
Humidity:	10% to 90% (non-condensing)
Ventilation Control Relays:	125 VAC, 50/60 Hz. 5 Amp resistive 250 VA inductive 1/8 HP motor
	24 VAC, 50/60 Hz. 5 Amp Resistive 24 VA inductive
Internal Alarm:	106 dB @ 3.7 KHz. piezoelectric element
Front Panel Indicators:	Power (green LED) Low alert relay (red LED) High alert relay (red LED) Alarm (red LED) Sensor active (yellow LED) Concentration (four digit LCD)
Selectable Fan Settings:	2-speed motor fans 2 individual fans
Alert Levels:	7 field selectable choices
Delay Times:	0 to 7 minutes, both entrance and exit
Dimensions:	9.44" W x 6.29" H x 3.54" D (24 cm W x 16 cm H x 9 cm D)
Weight:	3 lbs. (1.4 Kg.)
Housing:	Gray, NEMA 1, polycarbonate plastic
Agency Acceptance:	ETL listed to UL 61010B-1 and CSA C22.2 No. 1010.1

Target Gas Specifications

The Brasch Gas Detector is available for monitoring several different target gases. Regulatory agencies have determined the threshold concentrations at which the gases become dangerous. Brasch Manufacturing Company has designed their detectors so that the measurement ranges for each target gas meet the agencies' requirements.

Each target gas, for which Brasch currently produces a detector, is listed below along with the relevant concentration specifications.

Carbon Monoxide

Full Scale Span:	200 PPM
Low Alert Settings:	
Switch Position	0 1 2 3 4 5 6 7
PPM CO	20 25 30 35 40 45 50 55
High Alert Settings:	100 PPM

Nitrogen Dioxide

Full Scale Span:	10.0 PPM
Low Alert Settings:	
Switch Position	0 1 2 3 4 5 6 7
PPM Nitrogen Dioxide	0.3 0.5 1.0 1.5 2.0 2.5 3.0 4.0
High Alert Settings:	5.0 PPM

Oxygen

Full Scale Span:	25.0 %
Low Alert Settings:	
Switch Position	0 1 2 3 4 5 6 7
% Oxygen	20.5 20.0 19.5 19.0 18.5 18.0 17.5 17.0
High Alert Settings:	16.0 %

Description of Front Panel Indicators

The front panel indicators convey to the user the operational status of the detector. The following table describes the function of each indicator. Please refer to the detector's front panel label for the indicator's location.

Front Panel Indicators

Indicator	Description
Power Lamp	Glows green whenever power is on.
Low Alert Lamp	Flashes on short, off long when low alert level is exceeded and delay is active. Flashes on long, off short whenever concentration drops below low alert level and delay is active. Glows continuously when low alert relay contacts are closed.
High Alert Lamp	Flashes on short, off long when high alert level is exceeded and delay is active. Flashes on long, off short whenever concentration drops below high alert level and delay is active. Glows continuously when high alert relay contacts are closed.
Alarm Lamp	Glows continuously when alarm relay contacts are closed. Flashes to indicate a failed sensor condition.
SENS A / SENS B Lamps	Active Sensor Indicator. Glows continuously when that sensor's concentration is displayed.
Four Digit Display	Indicates the concentration associated with the active sensor lamp.

How the Detector Senses the Target Gas

Ambient air surrounding the detector housing diffuses inside the housing where it comes into contact with the sensor. Although the detector's circuitry dissipates very little power, a small amount of heat is produced inside the housing, rises and leaves the housing through the top two vents. This causes cooler air to enter the housing through the two vents on the bottom side of the housing. Any target gas present in this air causes a response from the sensor. If the detector is located properly, the sensor will respond to the average amount of the target gas present in the area. For help in properly locating the detector, please read the mounting guidelines on **page 1**.

This detector monitors the actual concentration of the target gas exposed to the sensor. This actual value may be different than the time-weighted-average values displayed by most of the personal gas monitors. Please take this difference into account when comparing the response of the two units.

A new target gas reading is taken and displayed every 4 seconds when only one sensor is installed. If two sensors are installed, the reading is updated every 8 seconds.

Obtaining the Best Operation

Carbon Monoxide and/or Nitrogen Dioxide Detectors

These detectors are designed to control the ventilation system in response to a rising concentration of the target gas.

No two installations will be exactly the same. Different ventilation components, the number of gas producing sources, air flow patterns inside the room, the total room volume and the exact location of the detector(s) influence how effective the system is in controlling the target gas concentration. The ideal operation occurs at detector settings that remove the most target gas without unnecessarily operating the ventilation system.

The detector has two variables that can be adjusted to obtain the best performance under the conditions it is operating. The target gas concentration at which the fans begin to operate is adjustable in 8 steps. Also, there is an adjustable time setting that delays the activation of the fans. This delay assures that transient levels of gas do not cause the fans to operate for short periods of time. This delay is adjustable from 0 to 7 minutes in 8 steps of one minute each. The delay period occurs between the time the "LOW ALERT" level is exceeded and the fans activate, and between the time the target gas concentration drops below the "LOW ALERT" level and the fans turn off. While the delay is in progress, the appropriate alert indicator will flash as the time proceeds toward zero.

The detector is shipped from the factory with the "LOW ALERT" concentration set at position 3, (**see page 7**), and the delay set at 3 minutes. These settings provide a good starting point. If the target gas concentration appears to continue rising after the fans activate, fine tune the settings by reducing the "LOW ALERT" setting or the activation delay. If the fans operate too often and/or for short periods, increase the activation delay.

In some cases, you may find that a target gas source is too close to the detector. Consider other mounting locations for the detector, or move the gas source farther away.

Oxygen Detector

This detector is designed to respond to a decreasing concentration of oxygen. Usually the detector will operate a ventilation system to bring fresh air, at a normal oxygen concentration, into the area being monitored. In other instances, the detector may only be used to sound an alarm allowing workers to evacuate the area.

The detector has two variables that can be adjusted to obtain the best performance under the conditions it is operating. The oxygen concentration at which the ventilation system or alarm activates is adjustable in 8 decreasing levels. Also, there is an adjustable time setting that delays the activation of the fans or alarm. This delay assures that transient low levels of oxygen do not cause the fans or alarm to activate for short periods of time. This delay can be adjusted for 0, 12, 30, 60, 120, 240, 360 and 600 seconds. The delay period occurs between the time the "LOW ALERT" level is exceeded and the fans, or alarms, activate, and between the time the oxygen concentration rises above the "LOW ALERT" level and the fans, or alarms, turn off. While the delay is in progress, the appropriate alert indicator will flash as the time proceeds toward zero.

The detector is shipped from the factory with the "LOW ALERT" concentration set at position 3, (**see page 7**), and the delay set at 60 seconds. These settings provide a good starting point. If the oxygen concentration appears to continue dropping after the fans activate, fine tune the settings by increasing the "LOW ALERT" setting or decreasing the activation delay. If the fans operate too often and/or for short periods, increase the activation delay.

Fig. 1: Typical wiring for single fan ventilation system.

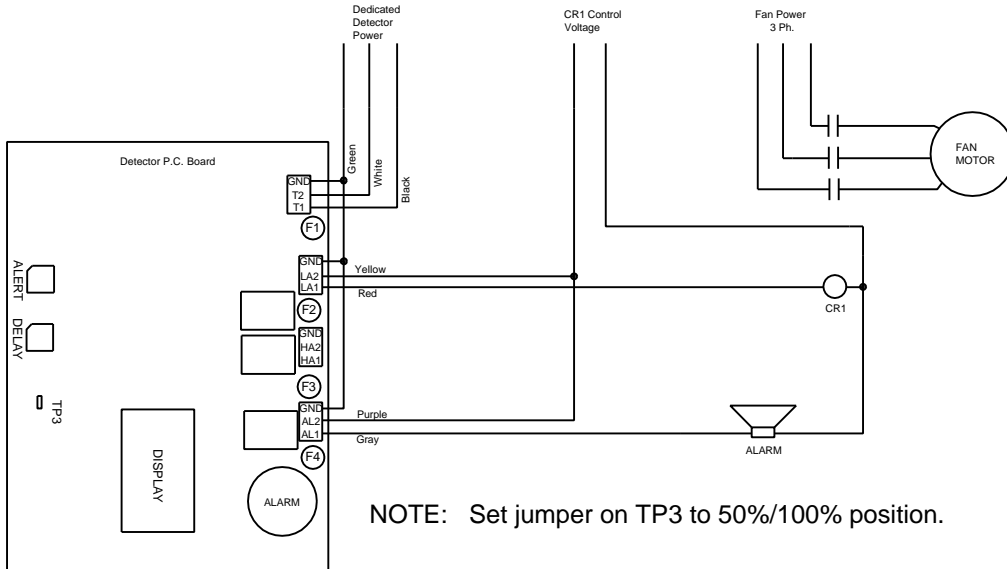

Fig. 2: Typical wiring for single fan ventilation system with auto/manual switch.

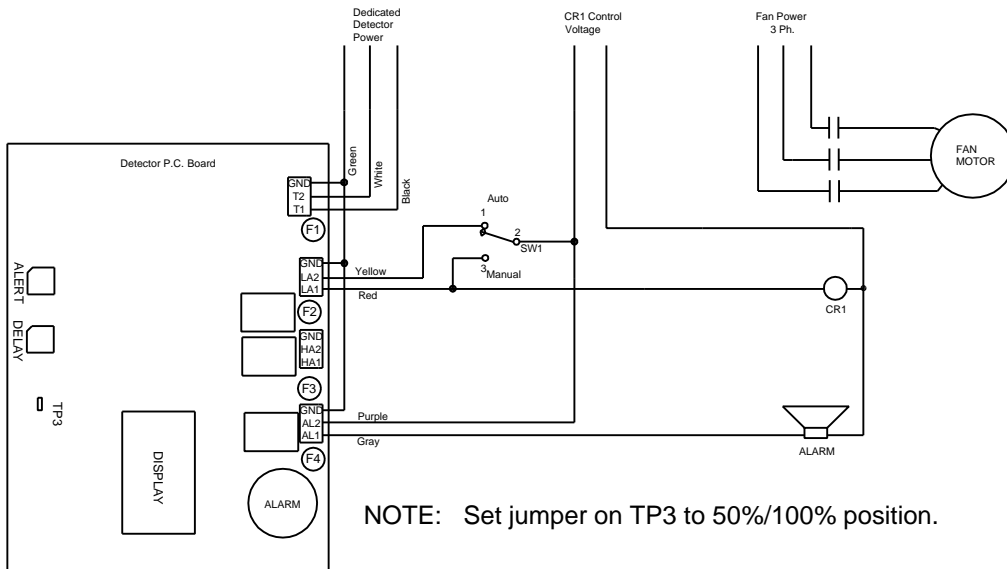
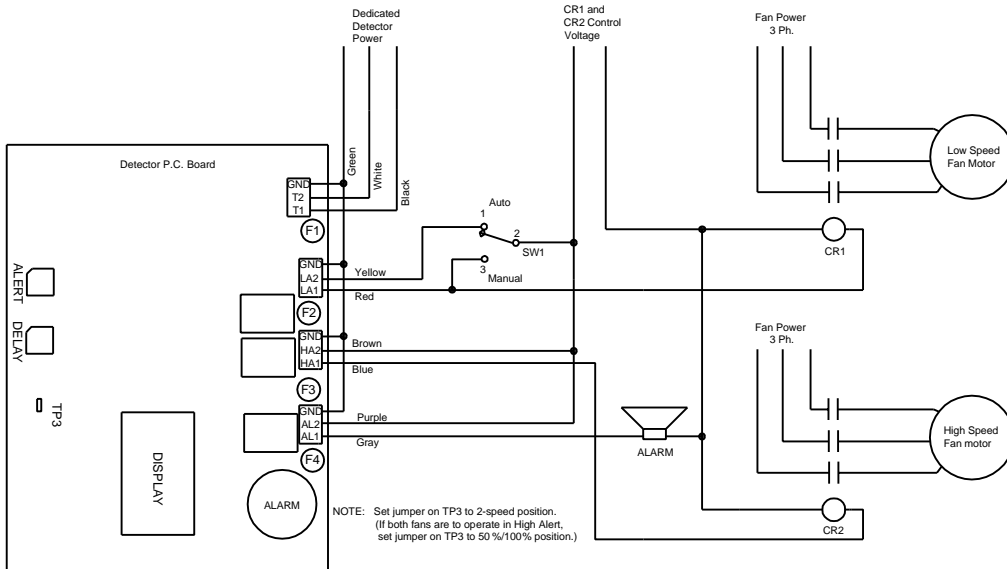

Fig. 3: Typical wiring for two fan ventilation system with auto/manual switch.



PART THREE – TROUBLESHOOTING and MAINTENANCE

Testing the Response to the Target Gas

Carbon Monoxide or Nitrogen Dioxide Detectors

Testing these detectors require that the target gas be applied to the sensor using one of two methods. Gas can be applied from a tank of air containing a known concentration of the target gas, or a level of target gas sufficient to activate the detector can be produced from the exhaust of an operating engine. Use a gasoline engine to produce CO and a diesel engine to produce nitrogen dioxide.

Of the two methods of obtaining test gas, the simplest is operating an engine in the vicinity of the detector under test. The engine should be placed about 10 feet away from the detector so that exhaust gases will not contact the detector directly.

Caution

Allowing the detector to come in direct contact with undiluted exhaust gases will decrease the expected useful lifetime of the sensor. The high concentration of acids and other components in the exhaust gas will overload the activated carbon filter inside the detector and will increase the effects of interfering gases upon the accuracy of the sensor.

If the sensor becomes damaged, it must be replaced with a new sensor calibrated at the factory.

The engine should be allowed to operate until a level of the target gas is displayed on the detector that is sufficient to activate the ventilation system. Depending upon the "LOW ALERT" and "DELAY" switch settings, and the volume of the area where the detector is located, this may take from ten to 30 minutes.

Using test gas applied from a tank has the advantage of speed as well as assurance that the detector is responding to the target gas. However, the gas must be applied directly to the sensor if the response is to be close to the value present in the tank. The test gas can not be allowed to become diluted by the air in the room before it comes in contact with the sensor. This reduces the concentration to a level too low to give the desired result.

While test gas is readily available for CO, gas containing low PPM levels of nitrogen dioxide is not available.

When testing the CO sensor response using test gas from a tank, the gas is allowed to flow through a flexible hose into the detector housing. Allow 20 to 30 minutes for the test gas to completely replace the air inside the detector housing. If the test gas has the required concentration of CO, the detector should respond by displaying a concentration and activating the appropriate ventilation component.

Because of the uncontrolled conditions in the test area, the detector will probably not indicate a concentration equal to that of the test gas. However, sufficient response can be obtained to determine that the detector is working.

Oxygen Detectors

The response of the oxygen sensor is checked by exposing the detector to room air having a normal concentration of oxygen. Ambient air should contain 20.9 % oxygen. Therefore, if the display reading is close to 20.9 %, the detector is responding correctly to the oxygen level in the area.

If the ventilation system operation is to be tested, a tank containing the appropriate concentration of oxygen must be used. Flow from this tank is allowed to enter the detector housing until it completely replaces the existing air in the housing. This process may take 20 to 30 minutes depending upon conditions in the test area. Because of the dilution effect of air currents in the room, the detector may display a concentration less than that specified on the tank data sheet.

Checking and Replacing Fuses

The circuitry of all the detectors are protected by time-lag TR5 fuses. They are UL rated at 250 VAC, and manufactured by Wickmann, series 374.

There are four fuses on the control board. F1 protects the control board circuitry and has a rating of 0.125 Amp if the detector operates from 125 VAC. If the detector operates from 24 VAC, F1 has a rating of 0.500 Amps. Information concerning the operation voltage, amperage and input power is found on the upper right of the front panel label, as well as on the control board directly below the power input terminal strip, TS7.

Each pair of control relay contacts are protected by a TR5 time-lag fuse rated at 5.0 Amps. These fuses are labeled F2, F3 and F4, and are located at the top edge of the control board.

Test these fuses by removing them from their holders after disconnecting all power sources. Measure for a low value of resistance across the pins. Replace any fuse that does not have a resistance reading near 0 ohms. Always replace fuses with one having the same ratings and characteristics.

Two more TR5 time-lag fuses protect the input circuitry of the sensor P.C. board. To access these fuses, the detector P.C. board assembly must be removed from the housing. Remove all power sources, disconnect the wiring at TS7, TS4, TS5 and TS6, remove the two securing screws at each end of the aluminum support plate and carefully remove the assembly by lifting straight up. Carefully turn the assembly on its top edge lengthwise to access the fuses on the sensor board. These fuses are labeled F1 and F2 and are rated at 0.200 Amps. Test each fuse for resistance and replace if the reading is not near 0 ohms.

Replacing the Sensor

The sensor's useful lifetime depends greatly upon its operating conditions. Continuous operation around large or numerous gas sources may shorten the sensor's useful life. **A recommended replacement date is recorded in the upper right corner of the front panel label.**

Because each sensor requires individual calibration, the sensor is replaced by installing a new, calibrated sensor board assembly. This procedure can be accomplished in the field. The old sensor board assembly may be discarded.

Please refer to the assembly drawings in the Appendix of this manual while removing and installing the sensor board assembly.

To replace the sensor board assembly, remove all detector power sources and remove the detector P.C. board assembly from the housing after removing the four securing screws from the aluminum support plate. Carefully lay the assembly on its top edge to expose the sensor P.C. board. Remove the four securing screws from the sensor board and unplug the flex cable from the control board. Plug the cable attached to the replacement sensor board onto the control board connector. After making sure that the sensor is firmly seated on the sensor board, place the board in position, with the sensor toward the aluminum support plate, and secure the board with the four mounting screws.

Slide the detector P.C. board assembly into the housing and install the four securing screws. Connect the power supply and ventilation control wires according to the order indicated on the wiring diagrams located on **page 10**. Carefully replace the cover after aligning the indicator lamps and “ALM. OFF/TEST” switch, and firmly tighten the six cover retaining screws. Restore the detector power sources and check for proper operation. See “Applying Power for the First Time” and “Using the Self-Test Feature” on **page 4**.

Suggested Repair Parts

The Brasch Gas Detector contains few field serviceable parts. However, the fuses are replaceable in the field. While an open fuse may indicate problems with the P.C. board circuitry, fuses may also open because of power surges or ventilation component failure. Therefore, Brasch Manufacturing Company recommends that the following fuses be available for replacement.

Qty.	Description	Part Number
5 ea.	Fuse, TR5, time-lag, 5.0 Amp, 250 VAC.	TR5-5.0
3 ea.	Fuse, TR5, time-lag, 0.125 Amp, 250 VAC., (if detector operates from 125 VAC)	TR5-0.125
3 ea.	Fuse, TR5, time-lag, 0.500 Amp, 250 VAC., (if detector operates from 24 VAC)	TR5-0.500
5 ea.	Fuse, TR5, time-lag, 0.200 Amp, 250 VAC., (sensor board fuses)	TR5-0.200

A package containing the proper quantities of fuses can be purchased through your Brasch distributor.

PART FOUR – COMMON INSTALLATION/OPERATION MISTAKES

Ventilation Components Connected to the Wrong Relays

A common mistake is to control a single fan ventilation system using the HI1 and HI2 relay contacts. If connected this way, the fan will not activate until the target gas concentration exceeds “HIGH ALERT” level. Unless you intend that the ventilation system activate only above the “HIGH ALERT” level, operate this type of ventilation system using the LA1 and LA2 relays contacts. Place jumper TP3 in the “50/100 %” position so that the fan will continue to operate if the target gas concentration exceeds the “HIGH ALERT” level.

Configuration Jumper in Wrong Position

On a single fan ventilation system, the fan is controlled from the LA1 and LA2 relay contacts. The fan will activate whenever the target gas concentration exceeds the adjustable “LOW ALERT” setting. However, if the jumper on TP3 is positioned in the “2-speed” setting, the fan will turn off if the target gas concentration exceeds the “HIGH ALERT” level. Therefore, when controlling a single fan system, place the jumper on TP3 in the “50/100 %” position.

The “2-speed” position on TP3 is used for two speed fan motors, or on two fan systems in which the low speed fan is to turn off if the high speed fan turns on.

Low Alert Level Set at Wrong Concentration

A common tendency is to set the “LOW ALERT” concentration at the lowest setting. A low alert setting that is too low can cause frequent cycling of the ventilation system. Always follow the regulatory agencies’ requirements, but set the low alert concentration to that which produces the most efficient ventilation system operation while protecting the workers in the monitored area.

Setting the “LOW ALERT” concentration too high can create a situation in which the target gas concentration becomes dangerous, or the area contains too much smoke from engine exhaust. Again, adjust the setting at a level that produces the best overall operation.

Delay Period Set Incorrectly

Using a long delay period can produce a situation in which a rapidly increasing gas level may rise to dangerous concentrations before the ventilation system activates. Also, smoke from the engine exhaust could build up to a point where workers’ eyes and noses may be affected. Choose a delay setting that activates the fans and begins to clear the area before the gas rises to a dangerous concentration, or eyes and nose irritation happens.

Setting the delay period too short will cause frequent operation of the ventilation system. The detector may activate the fans after sensing a transient gas concentration. Once the fans activate, this transient level will drop quickly causing the detector to turn off the fans. The ventilation system operates frequently and wastes energy. Increase the delay setting until a compromise is reached that keeps the target gas level below that specified in the regulatory standards without operating the ventilation system too often.

Detector Mounted In An Unsatisfactory Location

For reliable operation, the detector(s) must be mounted in the proper locations. Please read “Mounting the Detector” on **page 1** for guidelines on choosing locations.

Common mistakes include mounting a detector too close to a garage door. When the door is open, rain may blow through the doorway and onto the detector housing. Another common mistake is to mount the detector in a location where it comes in direct contact with engine exhaust. The large amount of contaminants in engine exhaust can shorten the useful life of the sensor.

One more common mistake is to choose a mounting location that places the detector too near the outlet of air conditioners or heaters. Quick, drastic changes in ambient temperature can cause erratic shifts in the detector readings.

By following the mounting guidelines, much of the problems caused by improper mounting locations can be eliminated.

PART FIVE – LIMITED WARRANTY

Warranty Statement

Limited Warranty

Brasch Manufacturing Co., Inc warrants gas transmitters, gas detectors, gas detector control panels and accessories for a period of one year from the date of shipment against defects in material or workmanship. Should any evidence of defects in material or workmanship occur during the warranty period, Brasch Manufacturing Co., Inc. will repair or replace the affected product, **at its own discretion**, without charge. The company shall not be held responsible for any charges incurred with removal or replacement of allegedly defective equipment, nor for incidental or consequential damages.

Service and Repair Procedures

Our goal at Brasch Manufacturing is to produce products that constantly exceeds the requirements and expectations of our customers. One of the ways of meeting that goal is to produce products that never fail or require service. However, when we are notified of a problem with one of our products, it is our intention to address the problem as quickly and efficiently as possible.

Many problems that appear at first to be associated with the product can be solved without returning the product. If you experience a problem, and would like to discuss it with a factory service technician, you may call the number listed on the product label. You will be transferred to a technician specially trained to service that specific product. This technician will help you determine the most efficient way of solving the problem.

If service or repair of your Brasch product becomes necessary, an authorization request for returning the product to the Brasch factory must be obtained from our sales office. If you are an end user, please contact your Brasch distributor to initiate this request. The distributor, after obtaining a description of the problem, will contact the factory and request a **Return Goods Tag, (RGT)**, number. This number must be placed in a conspicuous location on the outside of the shipping package. **Without this RGT number, Brasch will not accept the shipment.** A brief description of the reason for returning the product should be included in the package. Without this description, repair may take longer than necessary.

You may at the time you request service, request an estimate on the time it will take for repair. The Brasch representative will give you an estimate based upon the information you provide. Although Brasch Manufacturing Company will repair and return your product in as short a time as possible, Brasch can not be held responsible for meeting repair estimates.

Part Six – Appendix

Model Numbers and Descriptions

Each Brasch Gas Detector is given a model number that describes the type(s) of target gas(es), the number of sensors installed, whether the sensors are mounted in the housing or mounted remotely and the operating voltage. This model number appears on the upper, right corner of the front panel label.

Use the following list to completely identify a detector once you know the model number.

Detector Model Number and Description

Model Description	Model Number	
	24 VAC	120 VAC
Carbon Monoxide Detector:		
1 ea. CO sensor mounted locally	GSE-CM-L0	GSE-CM-L1
2 ea. CO sensors, one local, one remote	GSE-CM-LR0	GSE-CM-LR1
2 ea. CO sensors, both remote	GSE-CM-RR0	GSE-CM-RR1
1 ea. CO sensor mounted remotely	GSE-CM-R0	GSE-CM-R1
Nitrogen Dioxide Detector:		
1 ea. ND sensor mounted locally	GSE-ND-L0	GSE-ND-L1
2 ea. ND sensors, one local, one remote	GSE-ND-LR0	GSE-ND-LR1
2 ea. ND sensors, both remote	GSE-ND-RR0	GSE-ND-RR1
1 ea. ND sensor mounted remotely	GSE-ND-R0	GSE-ND-R1
Oxygen Detector:		
1 ea. OX sensor mounted locally	GSE-OX-L0	GSE-OX-L1
2 ea. OX sensors, one local, one remote	GSE-OX-LR0	GSE-OX-LR1
2 ea. OX sensors both remote	GSE-OX-RR0	GSE-OX-RR1
1 ea. OX sensor mounted remotely	GSE-OX-R0	GSE-OX-R1
Combination Nitrogen Dioxide/Carbon Monoxide Detector:		
Both sensors mounted locally	GSE-NCM-LL0	GSE-NCM-LL1
Both sensors mounted remotely	GSE-NCM-RR0	GSE-NCM-RR1
Nitrogen dioxide remote, carbon monoxide local,	GSE-NCM-RL0	GSE-NCM-RL1
Nitrogen dioxide local, carbon monoxide remote	GSE-NCM-LR0	GSE-NCM-LR1
Combination Oxygen/Carbon Monoxide Detector:		
Both sensors mounted locally	GSE-OCM-LL0	GSE-OCM-RL1
Both sensors mounted remotely	GSE-OCM-RR0	GSE-OCM-RR1
Oxygen remote, carbon monoxide local,	GSE-OCM-RL0	GSE-OCM-RL1
Oxygen local, carbon monoxide remote	GSE-OCM-LR0	GSE-OCM-LR1

Combination Oxygen/Nitrogen Dioxide Detector:

Both sensors mounted locally

GSE-OND-LL0

GSE-OND-LL1

Both sensors mounted remotely

GSE-OND-RR0

GSE-OND-RR1

Oxygen remote, nitrogen dioxide local,

GSE-OND-RL0

GSE-OND-RL1

Oxygen local, nitrogen dioxide remote,

GSE-OND-LR0

GSE-OND-LR1

GS = Gas Sensor

E = electrochemical carbon monoxide sensor

L = locally mounted sensor

R = remotely mounted sensor

1 = 120 VAC model, 0 = 24 VAC model

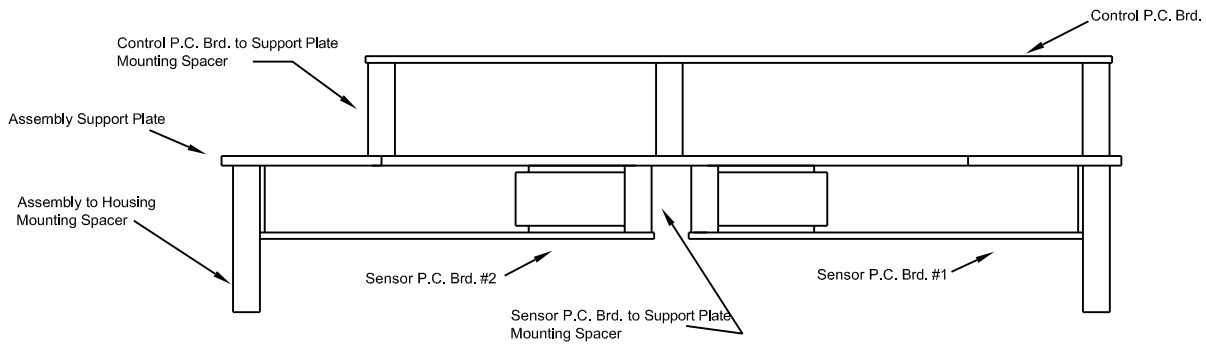

Fig. 4: Assembly View, GSE detector P.C. Board/support plate.

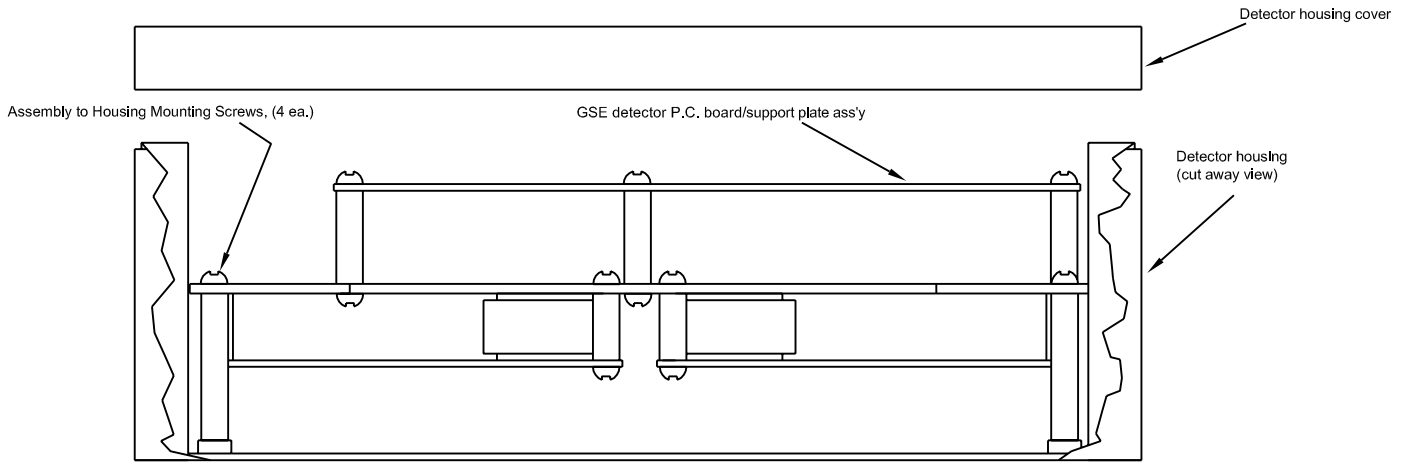

Fig. 5: Assembly View, GSE Gas Detector

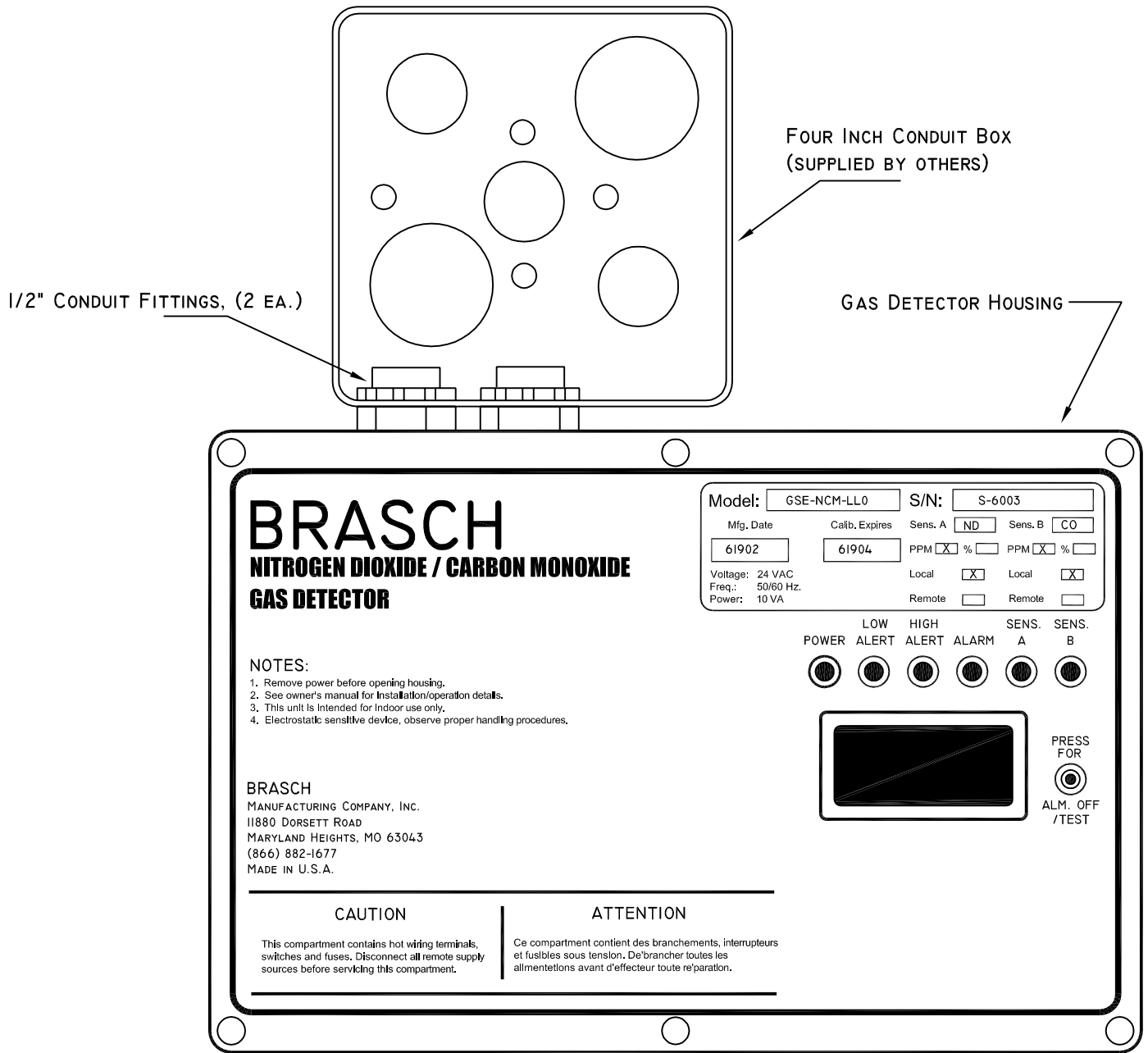

FIG. 6: MOUNTING VIEW
 GAS DETECTOR TO CONDUIT BOX

Using the Proportional Outputs

This Brasch gas detector is supplied with a linear output for each sensor that can be connected to a building management controller. These outputs can produce either a current or voltage signal that is proportional to the concentration of the target gas present at the sensor. By moving jumpers, located on the sensor P.C. board, the user can select from 4-20 ma current, 0-10 Vdc, 0-5 Vdc or 0-1 Vdc signals. This signal is available at terminal strips TS3 and TS4 on the detector control board. See Fig. 7, on **page 22**, for the terminal strip locations. For gas detectors with one sensor, the output is available at TS3 only, while TS2 is inactive. See Fig. 8, on **page 22**, for the location of the signal mode selection jumpers on the sensor P.C. board.

The detector is shipped from the factory with the selection jumpers set in the 4-20 ma current loop mode. To change the mode to one of the voltage modes, the detector P.C. board/support plate assembly must be removed from the detector housing in order to access the sensor P.C. board. After turning off all power sources to the detector, remove the six housing cover attaching screws to expose the P.C. board/support plate assembly. Refer to Fig. 5, on **page 19**, to locate the four assembly-to-housing mounting screws. Using Fig. 8, on **page 22**, arrange the jumpers on TP3 and TP4 of the sensor P.C. board for the required output. After making the selection, secure the P.C. board/support plate assembly into the housing by replacing the four mounting screws.

The output signal is connected to the building management controller using a two-conductor, shielded cable. The resistance of the total cable length must be less than 250 ohms if the 4-20 ma current loop mode is selected. For the voltage modes, the input impedance of the building management controller must be greater than 100 Kohms.

Ground the shield of the signal cable at the controller earth grounding point only to avoid noise conditions created by ground loops. Although the positive signal lead can be shorted to ground without causing damage, this condition should be avoided. Also, do not route the signal cable in conduit containing other wiring to avoid unwanted noise pickup.

The linear outputs produce a signal based upon the full scale response of the detector. See the section on target gas specifications on **page 7** of this manual.

As an example, a Brasch carbon monoxide detector has a full scale output of 200 PPM CO. For the 4-20 ma output mode, zero PPM CO would equal 4 ma, and 200 PPM CO would equal 20 ma. Follow the instructions supplied with the building management controller to adjust the controller's input for the proper scaling of the signal. Consider a zero ma, or zero Vdc, output as a failed sensor indication.

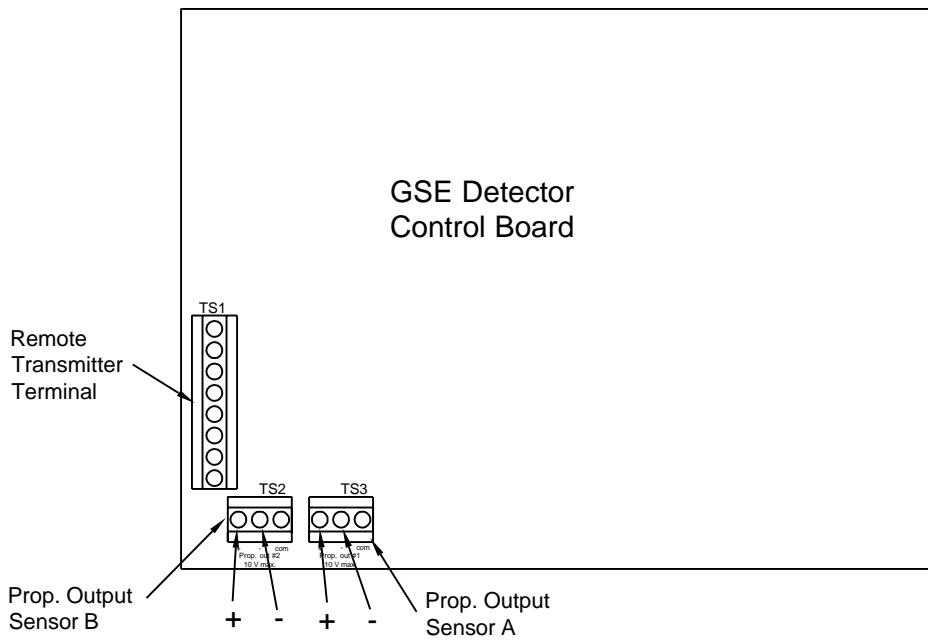

Fig. 7: Location of GSE proportional output terminals.

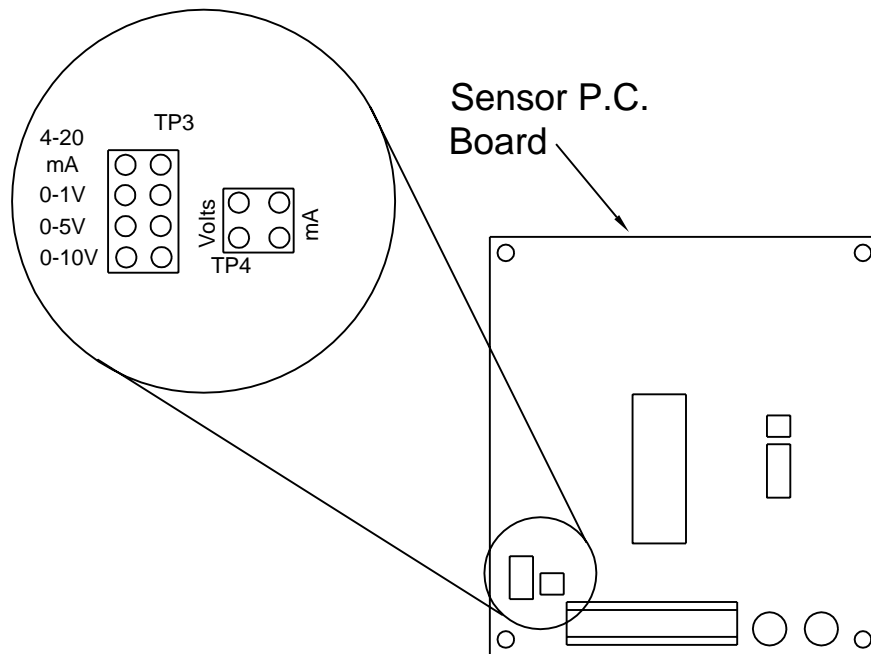

Fig. 8: Proportional output selection terminals on GSE sensor board.